

Structural Analysis Toolkit for NASTRAN

Best-in-Class Base-Driven Random Vibration Simulation

Results in seconds instead of hours

Save time, explore more scenarios,
and innovate faster

Structural Analysis Toolkit (SAToolkit) for NASTRAN delivers efficiency and accuracy where other software solutions struggle.

With extensive applications in space systems, electronics and automotive, SAToolkit provides advanced post-processing capabilities for general analyses and state-of-the-art analytical tools for base-driven dynamic simulation.

SAToolkit manages large results files that graphical post-processors can't.

M

Compare SAToolkit

- 200 times faster
- Equal or better accuracy
- Computes composite failure metrics



SAToolkit turned a 2-day analysis (200,000 elements model with 100 modes with 3 random vibs cases) using a competing product into a 6-minute job. Well worth the investment!

- William Villers, Director of Engineering, TEN TECH LLC



Random processor

Quickly simulate random shaker testing using large industrial models with many vibration modes, without worrying about data storage limitations. Simplify your simulations by eliminating the need to define too many or too few integration frequencies.

Maya HTT's SAToolkit features a parallelized random processor that reads the results of a NASTRAN normal modes (SOL 103) solution and evaluates the responses of a structure subjected to a random base acceleration.

- Uses efficient hybrid integration
- Computes peak derived stress and strain results, including Von Mises, principal and maximum shear
- Accounts for non-Gaussian probability distribution, with up to 30% greater accuracy
- Computes peak vector result magnitudes
- Automatically generates stress margins of safety
- Computes peak composite failure metrics
- Efficiently accounts for modal truncation
- Supports Simcenter NASTRAN and MSC NASTRAN
- Runs on Windows and Linux
- Runs in batch

SATK now supports the Fatigue output request, which calculates fatigue damage and estimates life based on applied random excitations. You can choose between the Dirlik, Narrowband, or Steinberg methods to compute fatigue damage and life using a stress-life approach.

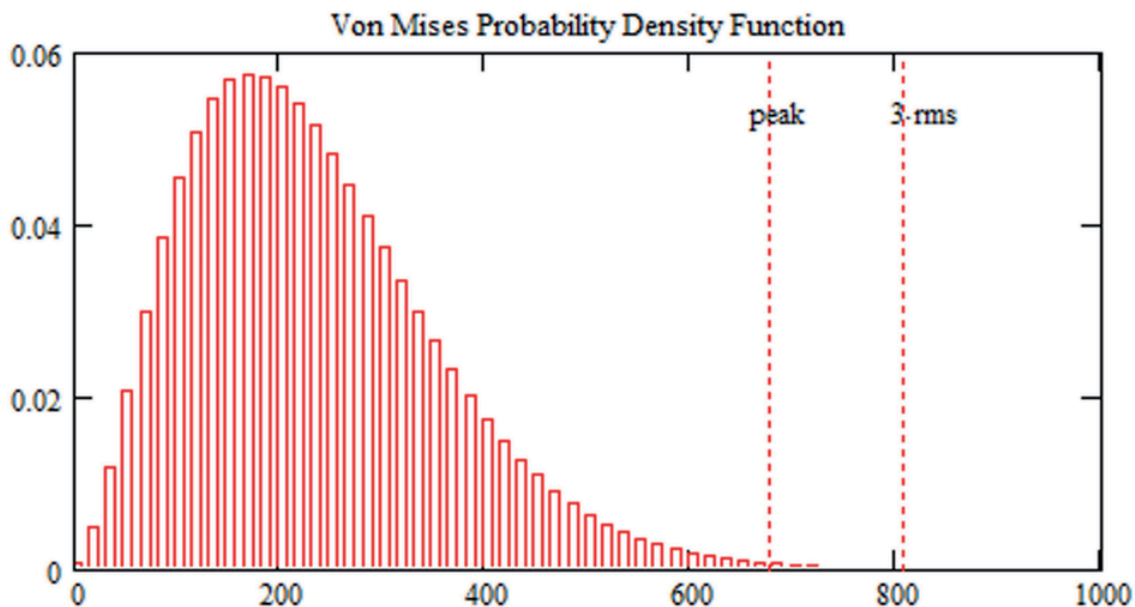

You can post-process SAToolkit's contour and XY graph results in Simcenter 3D Desktop and Simcenter FEMAP

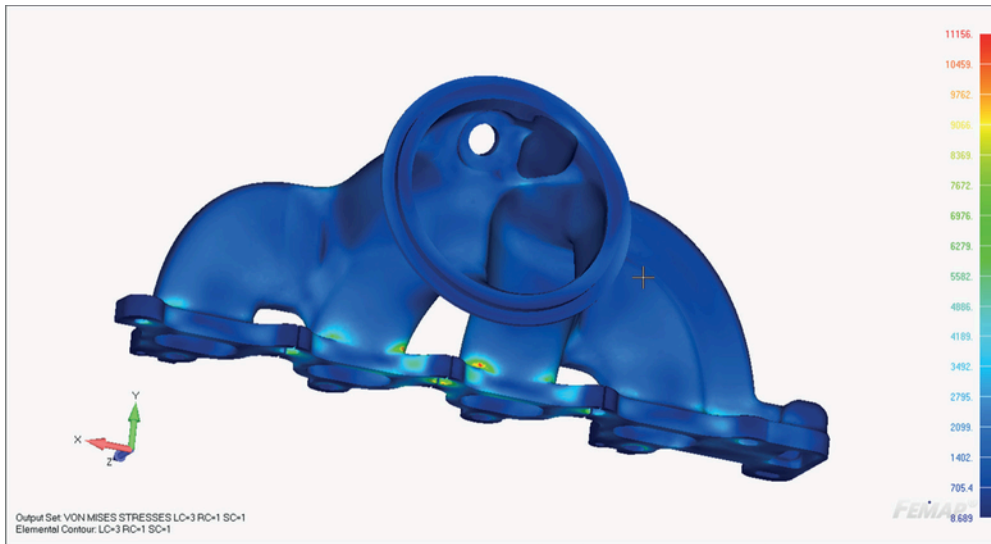

- › This model was solved in 120 minutes for 3 axes:
- 600,000 solid elements
 - 980,000 nodes
 - 250 modes

Yields identical basic nodal and elemental results as Nastran SOL 108 or 111

1_SpaceCraft_WP_RBE_s : RMS_FORCE_ACC_STRESS Result
 Load Case 1, Frequency 1, 0Hz
 Von Mises Stress [RMS] - Elemental, Averaged, Scalar
 Min : 0.00, Max : 828.70, Units = MPa

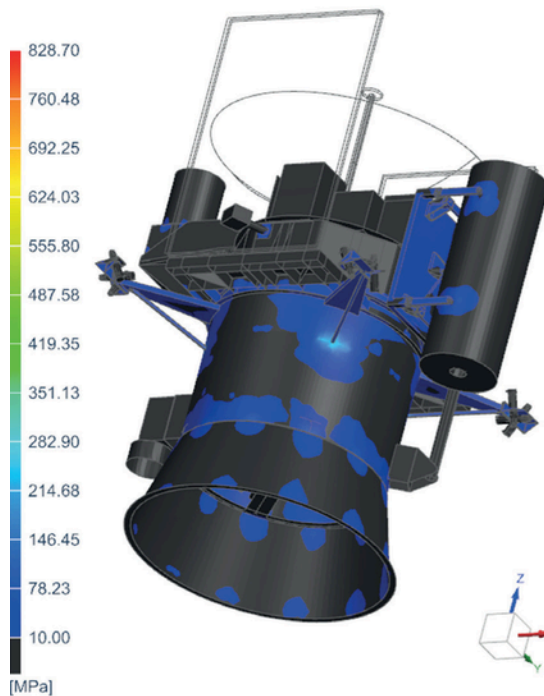

1_SpaceCraft_WP_RBE_s : SOL111 Result
 Subcase - Static Loads 1, Root Mean Square Results
 Root Mean Square Von-Mises Stress - Element-Nodal, Averaged, Scalar
 Beam Section : Recovery Point C, Shell Section : Top
 Min : 0.00, Max : 712.28, Units = MPa
 Coord sys : Native

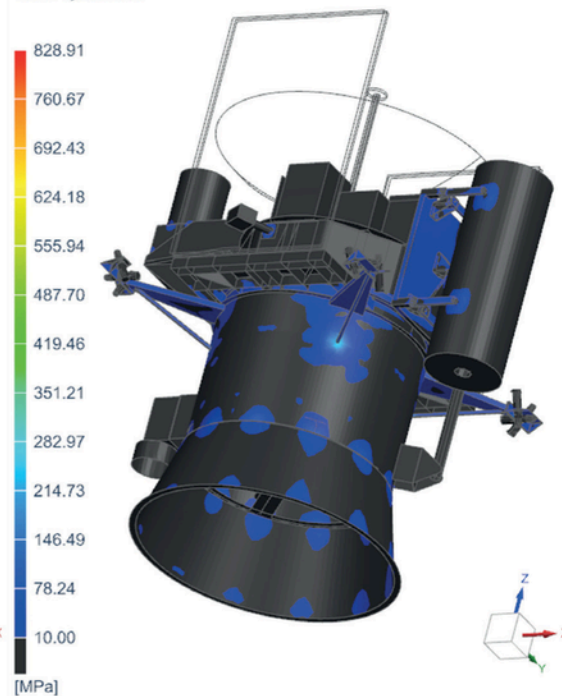

Modal summary

Use two criteria – effective mass and the structure’s response to base excitation – to assess the importance of a structure’s global and/or local modes.

SAToolkit’s modal summary tool:

- Processes the modal information from a normal modes (SOL 103) analysis
- Tabulates and graphs effective masses in Excel
- Tabulates acceleration responses for selected groups of nodes
- Automatically flags critical modes where effective masses and/or dynamic responses exceed user-defined thresholds

Stress and margin of safety processor

Enjoy more efficient assessment of minimum margins of safety for complex structures made from different materials and subjected to various loadings.

Designed to process large result files easily, the SAToolkit’s stress processor reads element stresses and calculates margins of safety based on:

- User-defined element groups
- Material strengths
- Safety factors

It processes NASTRAN static, transient, and frequency response results.

The stress processor supports several failure theories, including:

- Von Mises stress
- Honeycomb sandwich panel stress (intra-cell buckling, shear crimping, wrinkling)
- Laminate failure theories found on the PCOMP card



Energy processor

The energy processor measures strain energy per modes and groups.

SAToolkit's energy processor tool:

- Ranks strain and kinetic energy by group and by mode
- Promotes thorough understanding of modal behavior in complex models
- Displays both tabular and graphical results in formatted Excel worksheets

Strain Energy per Modes & Groups

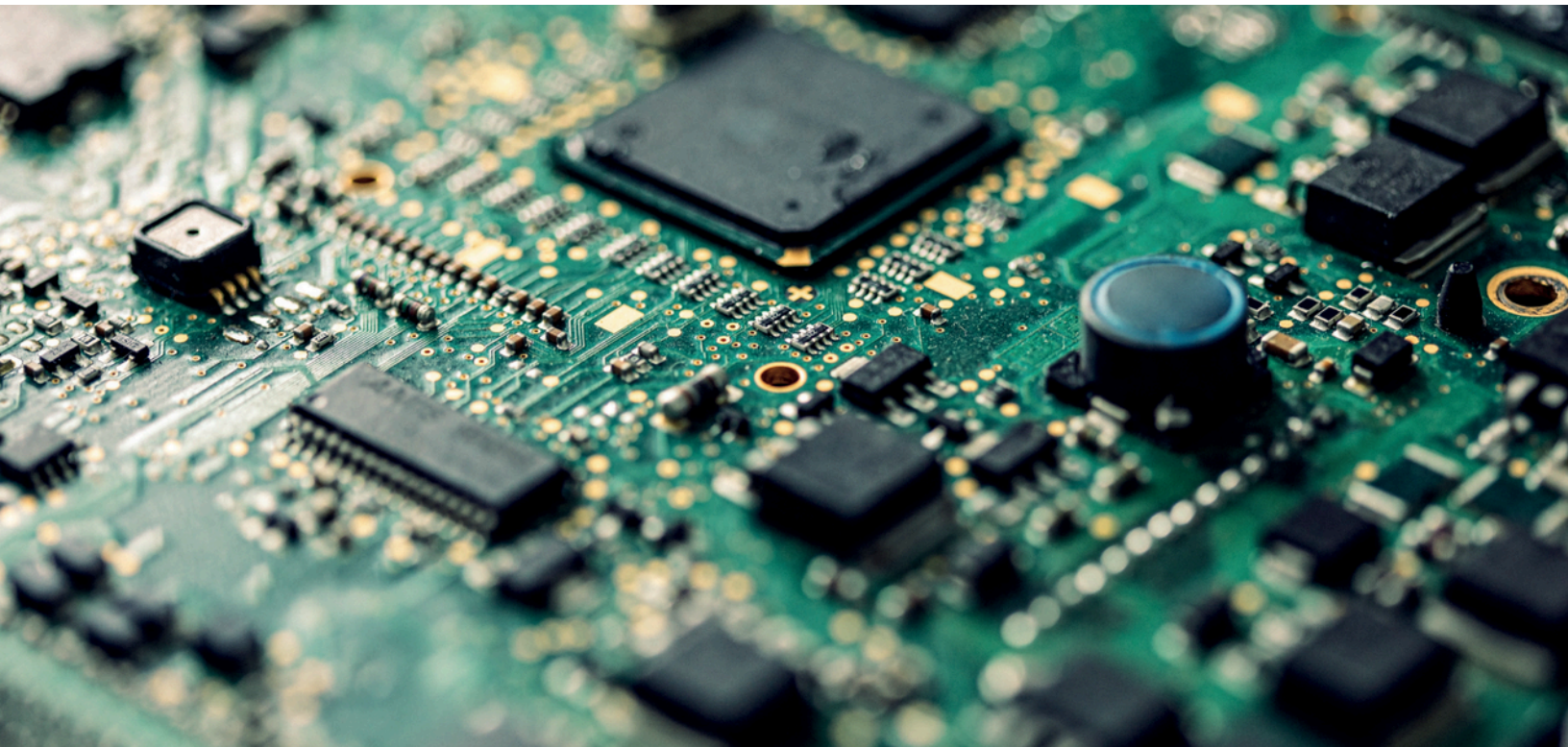
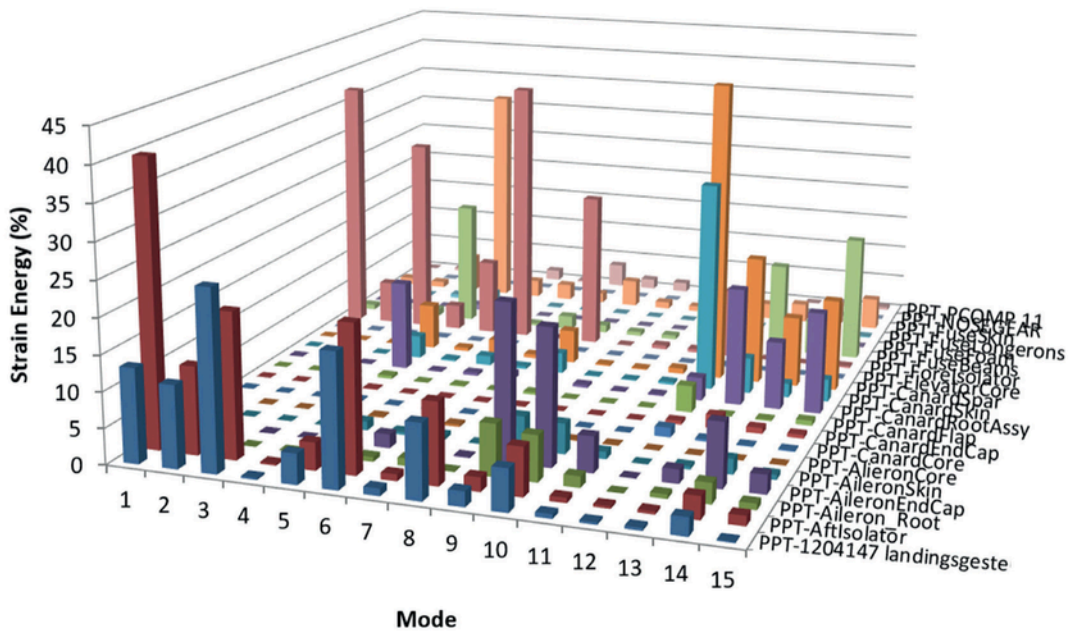

Sine processor

Simulate shaker sine tests easily. The sine processor performs steady-state harmonic base excitation analyses using Nastran SOL 103 results. SAToolkit's sine processor tool:

- Calculates phase-consistent maximum Von Mises stresses, derived stresses and strains, and vector magnitudes
- Computes laminate ply stresses, failure indices, and margins of safety
- Features a parallelized solver and can be run in batch
- Efficiently accounts for modal truncation

SATK now supports fatigue analysis for both sine dwell and sine sweep excitations using the Sine processor. For sine dwell, fatigue damage is evaluated at a specified excitation frequency. For sine sweep, fatigue damage is evaluated assuming a constant sweep rate.

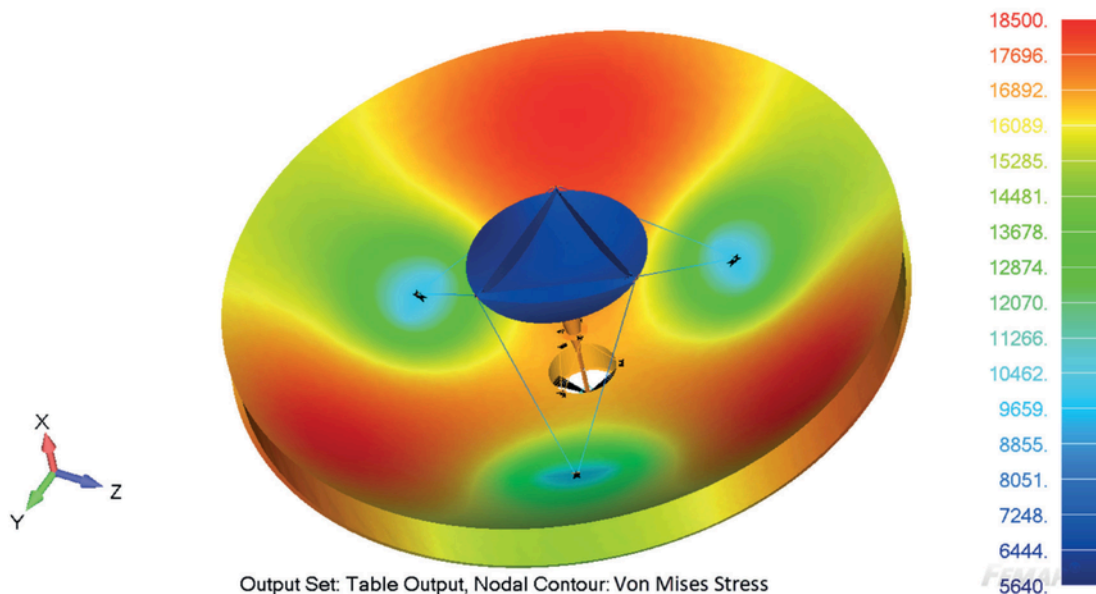

Element force processor

Perform detailed analyses by tabulating NASTRAN element forces according to the subcases and element groups you define.

SAToolkit's element force processor tool:

- Evaluates maximum forces in the entire finite element model (FEM) or in selected regions
- Identifies maximum force components along with associated element, subcase, and consistent forces
- Ranks forces easily in Excel

Grid point force processor

SAToolkit's grid point force processor tool permits efficient assessment of bolted and bonded joint integrity in large NASTRAN models over many subcases:

- Computes joint margins of safety thanks to the option to define structural joints and associated allowable load vectors
- Computes nodal and overall joint margins
- Includes Direct Matrix Abstraction Program (DMAP) that calculates grid point forces for dynamic and transient solutions
- Displays graphical margins



M

Read the technical white paper



Random Base Excitation Simulation: Benchmarking accuracy and performance with Structural Analysis Toolkit (SATK) for NASTRAN

Why choose SAToolkit?

Offering 200x the speed of competing solutions along with superior accuracy, SAToolkit is a must-have for random base excitation vibration simulation and structural analysis.

It is an excellent complement to Simcenter 3D Desktop and Simcenter FEMAP, easily handling even the largest result files in a snap.

SAToolkit:

- Runs on Windows and Linux
- Interfaces with Simcenter 3D Desktop and FEMAP for both pre- and post-processing
- Reads Simcenter and MSC NASTRAN .op2 files
- Automatically generates reports in Excel, HTML, and text formats
- Reads FEMAP groups
- Imports groups from NASTRAN SET cards
- Sends results to formatted Excel workbooks

Expert
Partner

Digital Industries Software

SIEMENS