

# Maya HTT

## SAToolkit Random Processor: Efficient and accurate random base excitation simulation

---

By  
Hadi Mahdavi  
Philippe Tremblay

# Table of Contents

1.	Introduction	03
2.	Random Events	04
3.	Linear Stress Analysis	05
4.	Random Theory	08
5.	Issues with traditional Random Analysis	11
6.	SAToolkit Random Processor	16
7.	Unprecedented efficiency and performance in random base excitation	31
8.	References	31

# 1. Introduction

Structures are subject to random vibrations in the form of base excitation, that is, application of a single random input at the base of a structure. Random base acceleration testing is prevalent in several industries. Today, there are various simulation tools that can predict structural responses to the base excitations, however their performance and accuracy have historically been problematic. Key issues include:

- The probabilistic nature of random theory which requires a costly integration step.
- Important derived quantities such as Von Mises stress do not respect random distribution assumptions.
- Potentially inadequate manual definitions of input frequencies.
- Workflow issues associated to requesting different result types, and having to post-process computed results to obtain meaningful engineering metrics.

In this paper, we'll take a close look at these issues, and we will see how the Random Processor of Maya HTT's Structural Analysis Toolkit (SAToolkit) addresses each one. We'll benchmark the Random Processor against Simcenter Nastran SOL 111 random subcase, demonstrating that it gives the same basic results, provides more accurate results for derived quantities, supports important quantities such as composite failure metrics, while requiring far less computation time.

We'll show that the SAToolkit Random Processor is the best-in-class tool for the simulation of base-driven random vibration that Nastran users can immediately migrate to.



## 2. Random Events

A random event is one in which the properties of the input signal are not known at any one time. However, the signal's statistics can be evaluated and are used to predict a structure's dynamic response.

### 2.1 Industrial relevance

Random events are structural design drivers in the automotive, space and electronics industries.

#### 2.1.1 Space

Rocket motors produce high levels of acoustic noise, which can exceed 140 db as far away from the pad as inside the launcher fairing. The pressure waves induce high vibro-acoustic responses in spacecraft structures with large surfaces, such as instrument panels. Panel-mounted units or components are excited via their interfaces to the panels.

The dynamic response of such a component is evaluated using random base excitation analysis: A random signal, typically an acceleration power spectral density (PSD), is applied at its base, which is assumed to be rigid.

#### 2.1.2 Automotive

Automotive components are subjected to vibration that is typically induced by the vehicle's response to road profiles. The trend for automakers and suppliers to perform random vibration analysis has increased in recent years, resulting in improved component reliability. Some examples include:

- Instrument panels
- Seats
- Air-bag sensors
- Fuel injection components
- Headlights, taillights and chmsls.

#### 2.1.3 Electronics

Random vibrations can adversely affect printed circuit board (PCB) performance, depending on the board's modal characteristics, structural damping, housing dynamics and vibration input. Performance of PCBs and electronic components is evaluated against random events in a wide range of applications such as consumer products.

# 3. Linear Stress Analysis

For metallic and other isotropic materials, quantities derived from stress tensors such as principal and Von Mises stresses are compared to published strength values to produce failure metrics. Computing these derived responses for a random event requires advanced algorithms and can be computationally expensive.

First ply failure (FPF) is a common linear analysis method in which the laminate is considered to have failed when the first ply fails. Using classical laminate theory, the stress components in each ply are determined and compared to orthotropic stress limits using an interaction equation.

Commonly derived quantities for both isotropic and orthotropic laminate materials are reviewed here.

## 3.1 Von Mises stress and failure metrics

Von Mises failure theory is widely used for metallic materials and is typically associated with the material's yield strength,  $S_Y$ . It can also be extended to the ultimate tensile strength of the isotropic material,  $S_U$ .

### 3.1.1 Von Mises Stress

- For a 2D material:

$$\sigma_{VM} = \sqrt{\sigma_x^2 + \sigma_y^2 - \sigma_x\sigma_y + 3\tau_{xy}^2}$$

- For a 3D material:

$$\sigma_{VM} = \sqrt{\frac{1}{2} \left[ (\sigma_x - \sigma_y)^2 + (\sigma_x - \sigma_z)^2 + (\sigma_y - \sigma_z)^2 + 6(\tau_{xy}^2 + \tau_{xz}^2 + \tau_{yz}^2) \right]}$$

### 3.1.2 Strength Ratio

The strength ratio SR is computed as follows:

Using the yield strength:  $SR = \frac{S_Y}{\sigma_{VM}}$

Using ultimate strength:  $SR = \frac{S_U}{\sigma_{VM}}$

### 3.1.3 Failure Index

The failure index  $F$  is the inverse of the strength ratio:  $F = \frac{1}{SR}$

### 3.1.4 Margin of Safety

The margin of safety  $MS$  is computed from the failure index as follows:

$$MS = \left( \frac{1.0}{FS \times F} - 1 \right) \times 100$$

Where  $FS$  is a safety factor.

## 3.2 Laminate first ply failure and Tsai-Wu criterion (2D)

The widely used Tsai-Wu failure criterion is presented here, in its 2D form.

### 3.2.1 Failure Index

The expression of the Tsai-Wu failure criterion is:

$$F = F_1\sigma_1 + F_{11}\sigma_1^2 + F_2\sigma_2 + F_{22}\sigma_2^2 + 2F_{12}\sigma_1\sigma_2 + F_{66}\tau_{12}^2 < 1.0$$

where  $F$  is the failure index and:

$$\begin{aligned} F_1 &= \frac{1}{X_T} - \frac{1}{X_C} \\ F_{11} &= \frac{1}{X_T X_C} \\ F_2 &= \frac{1}{Y_T} - \frac{1}{Y_C} \\ F_{22} &= \frac{1}{Y_T Y_C} \\ F_{66} &= \frac{1}{S^2} \end{aligned}$$

in which:

- $X_T$ : Tensile stress limit in 1-direction
- $X_C$ : Compressive stress limit in 1-direction
- $Y_T$ : Tensile stress limit in 2-direction
- $Y_C$ : Compressive stress limit in 2-direction
- $S$ : Shear stress limit in 12 plane

In the absence of test data, the following is recommended for defining the Tsai-Wu interaction coefficient,  $F_{12}$ :

$$F_{12} = -\frac{1}{2} \frac{1}{\sqrt{X_T X_C Y_T Y_C}} = -\frac{1}{2} \sqrt{F_{11} F_{22}}$$

The software performs the following stability check:

$$F_{11} F_{22} - F_{12}^2 > 0$$

If the stability check passes, the software uses the user-defined value for  $F_{12}$ . If the stability check fails, the software uses  $F_{12} = 0.0$ .

### 3.2.2 Margin of Safety

To calculate the Tsai-Wu margin of safety, we must first determine the value of the proportionality factor  $\alpha$  such that the state of stress given by  $\alpha\sigma_1$ ,  $\alpha\sigma_2$ , and  $\alpha\tau_{12}$  gives a failure index  $F$  of 1. To calculate the value of  $\alpha$ , we rewrite the first equation in this section:

$$F_1 \alpha \sigma_1 + F_{11} (\alpha \sigma_1)^2 + F_2 \alpha \sigma_2 + F_{22} (\alpha \sigma_2)^2 + 2F_{12} \alpha^2 \sigma_1 \sigma_2 + F_{66} (\alpha \tau_{12})^2 = 1.0$$

which is a quadratic equation in  $\alpha$  that can be rewritten:

$$A\alpha^2 + B\alpha + C = 0$$

where:

$$A = F_{11}\sigma_1^2 + F_{22}\sigma_2^2 + 2F_{12}\sigma_1\sigma_2 + F_{66}\tau_{12}^2$$

$$B = F_1\sigma_1 + F_2\sigma_2$$

$$C = -1$$

The solutions to this quadratic equation are:

$$\alpha_{1,2} = \frac{-B \pm \sqrt{B^2 + 4A}}{2A}$$

The software takes  $\alpha$  to be the smallest positive value between  $\alpha_1$  and  $\alpha_2$ . If both  $\alpha_1$  and  $\alpha_2$  are negative,  $\alpha$  is set to zero. The software calculates the margin of safety MS as follows:

$$MS = (\alpha/FS - 1) \times 100$$

Where FS is a safety factor.

### 3.2.3 Strength Ratio

The strength ratio SR is the proportionality factor  $\alpha$ :  $SR = \alpha$

# 4. Random Theory

Random events are not deterministic, that is, one cannot know the value of a random signal at any one time. If one measures a random signal many times, exactly repeating the experiment, with identical start time, duration, sampling interval, etc., one will get a different result each time! This is shown in Figure 1. However, the event can be quantified using statistical metrics such as a mean value and a standard deviation.

Random theory assumes the signal has a zero-mean and is stationary and ergodic:

- In stationary signals, the statistics of the environment do not change over time, i.e. ensemble statistics are same at  $t_1$  as at  $t_2$ , regardless of value of  $t_1$  or  $t_2$ .
- In an ergodic process the statistics of one sample over time are the same as the statistics across the entire ensemble at a particular time  $t_k$ . In other words, any individual sample can represent the entire random process.
- The signal's mean value is zero. This implies that offsets such as a static preload should not be considered in a random simulation.

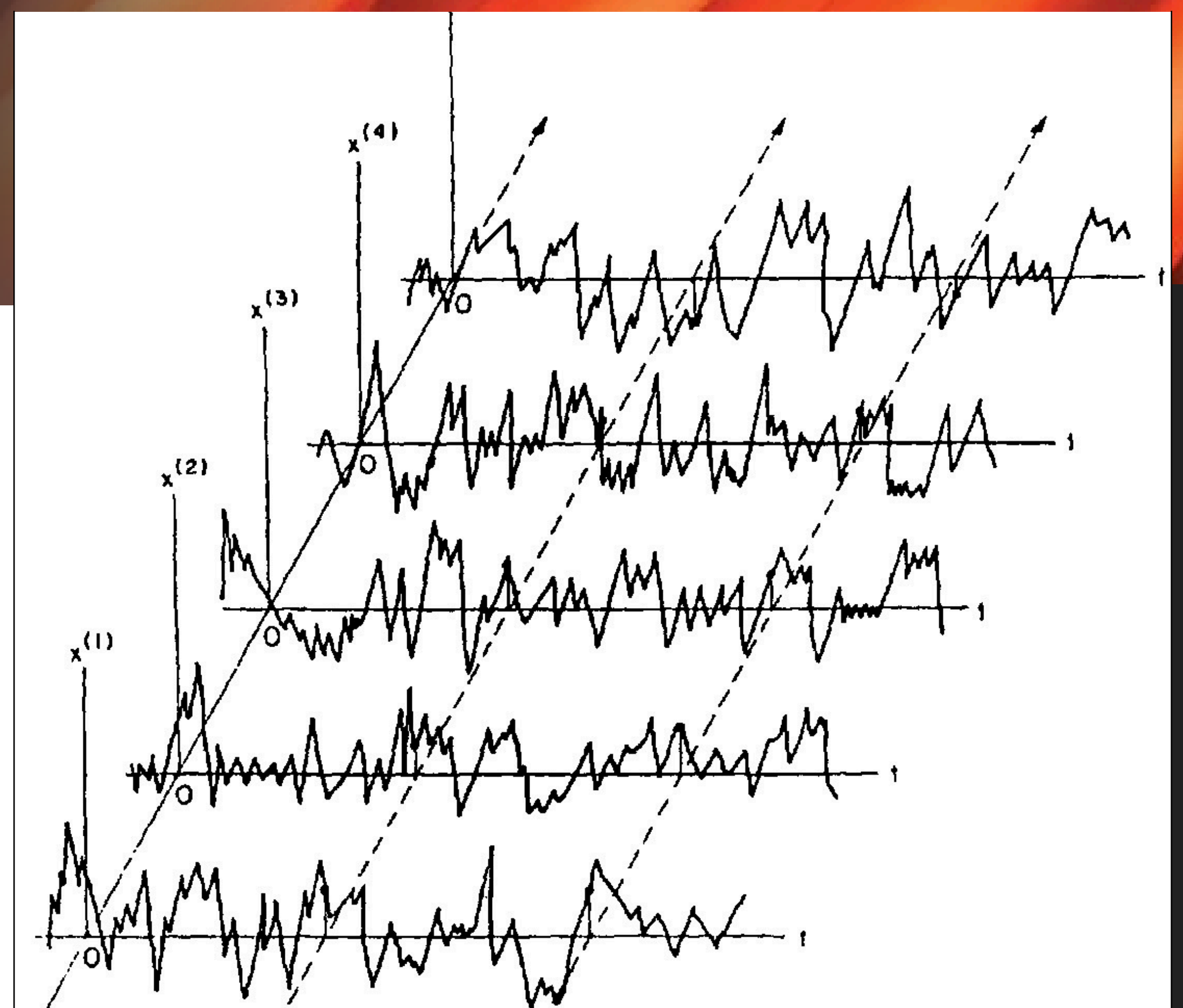

Figure 1: Random Process is Probabilistic, Not Deterministic.

## 4.1 Probability Density Function

Random analysis is about the probability of the signal being of a given magnitude. The graph in Figure 3 shows a probability density function (PDF)  $p(x)$ , defining the probability that a parameter  $x$  has a certain value during the event.

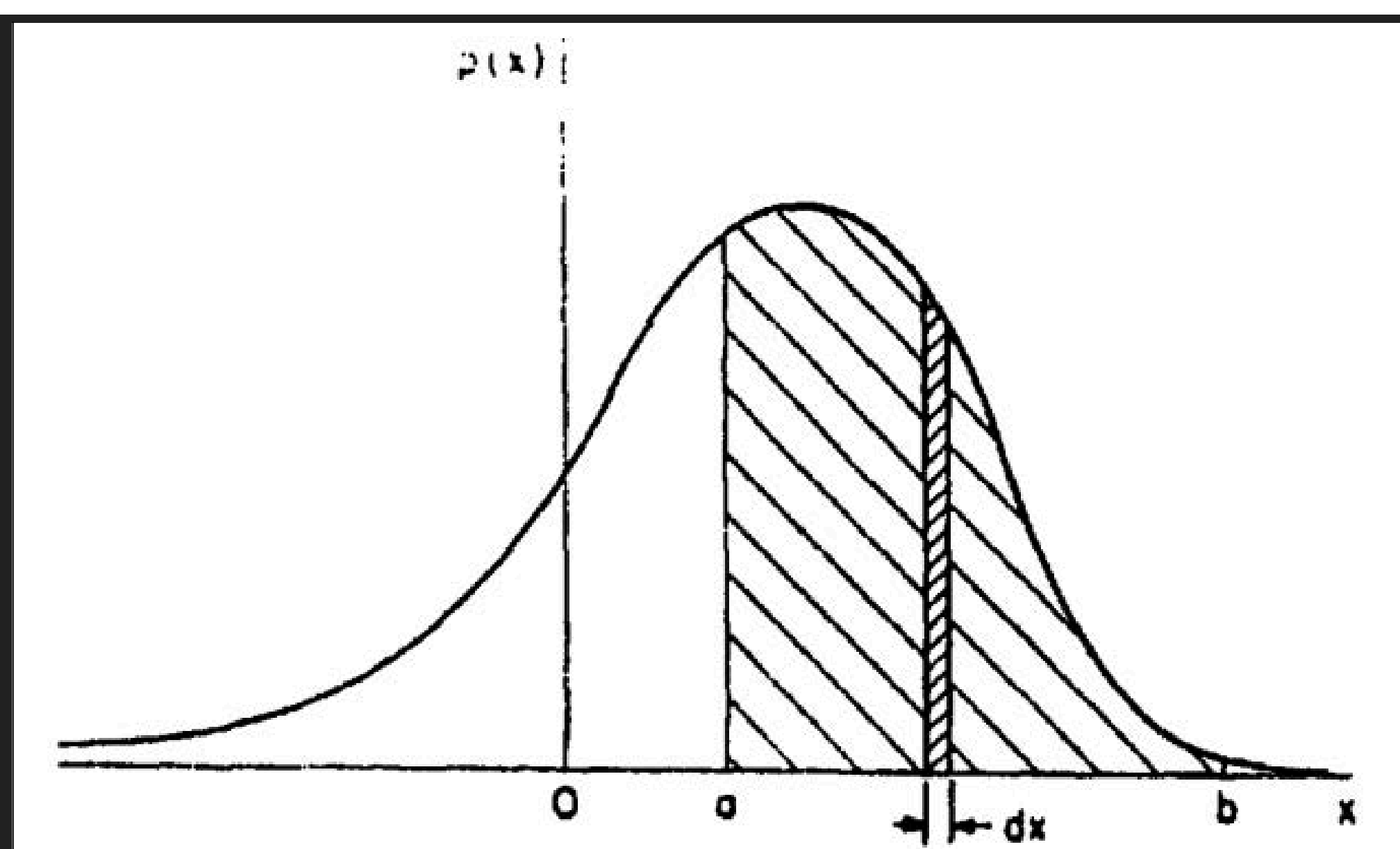

Figure 2: Probability Density Function of parameter X

Integrating the probability density function gives the probability that  $x$  lies between 2 values, for example  $a$  and  $b$ . This is defined by the area shown in the graph. If you integrate the PDF from  $-\infty$  to  $+\infty$ , this will give a value of 1. The cumulative probability distribution function (CDF)  $P_{(x_1)}$  is defined as

$$P(x_1) = \int_{-\infty}^{x_1} p(x) dx = \text{Prob}[x \leq x_1]$$

which is the integral of the probability density function  $p(x)$  with the lower limit set to  $-\infty$ ; it defines the confidence in  $x$  being less than or equal to a given value  $x_1$ .

Random event inputs are assumed to be zero-mean, stationary and Gaussian random signals, and are applied to linear finite element models. As a consequence of the model's linearity, the response will also follow a zero-mean, stationary and Gaussian distribution, as shown in Figure 3.

A Gaussian probability density function can be expressed as using the standard deviation  $\sigma$  and mean  $\mu$ :

$$p(x) = \frac{1}{\sigma\sqrt{2\pi}} e^{-\frac{(x-\mu)^2}{2\sigma^2}}$$

where  $\mu$  is assumed to be zero.

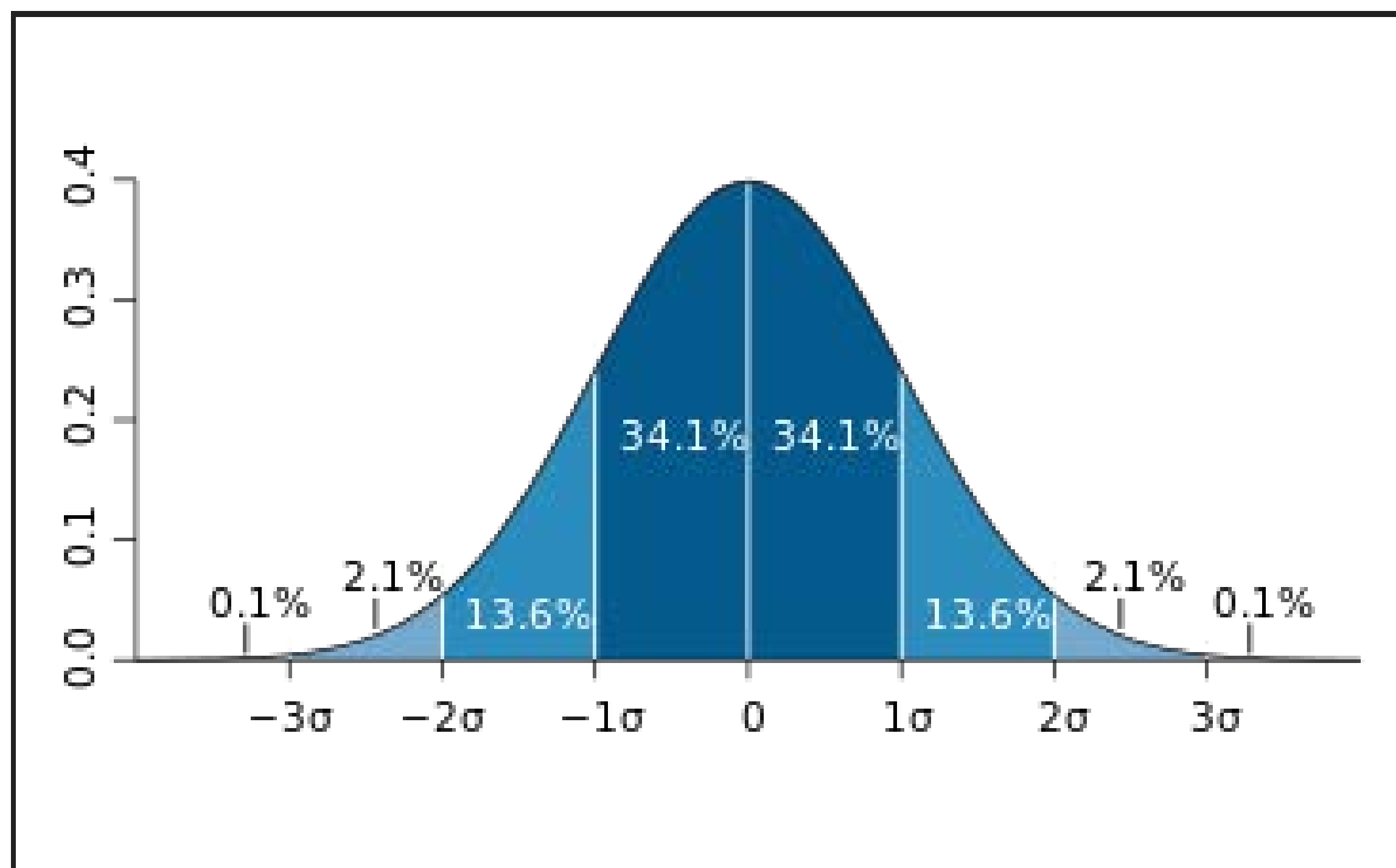

Figure 3: Normal (Gaussian) distribution curve, showing the probability as a function of standard deviation [Source: Wikipedia].

## 4.2 Confidence Level and Peak Results

For a Gaussian distribution, the probability of the signal being in a certain range is usually expressed as a scalar number of standard deviations  $\sigma$ . If we define  $\lambda$  as the number of standard deviations  $\sigma$  on the x axis of Figure 3, the confidence level can be obtained from the following formula, where erf is the error function:

$$\text{Confidence level (\%)} = \text{erf}\left(\frac{\lambda}{\sqrt{2}}\right)$$

Table 1 relates the confidence level to the number of standard deviations  $\lambda$ :

$\lambda$	Confidence Level	Probability of $ x  > \text{nce Level}$
1	68.2689 %	31.7311 %
2	95.4500 %	4.5500 %
3	99.7300 %	0.2700 % ( $\approx 0.3\%$ )
4	99.9937 %	0.0063 %
5	99.9999 %	0.0001 %

A commonly used confidence level is 99.73% which, for a Gaussian distribution, is achieved when the signal is within the  $[\mu-3\sigma, \mu+3\sigma]$  interval, or the  $[-3\sigma, 3\sigma]$  interval, since the mean is assumed to be zero. This interval is also referred to as the '3-sigma' interval. It should be noted that the root mean square (RMS) value of the signal equals its standard deviation  $\sigma$  when the mean is zero.

Output quantities associated with a specified confidence level are called Peak results. In the general case in which the results follow a zero-mean Gaussian distribution, Peak values can easily be computed by multiplying the RMS (or standard deviation) value by  $\lambda$ , which can also be referred to as the peak-to-RMS ratio.

Some common response quantities do not follow a Gaussian distribution, these are detailed in section 5: Their Peak values cannot be accurately obtained from their RMS values.

### 4.3 Random Base Excitation Response

The response power spectral density is computed as follows:

$$S(\omega) = \sum_{j=1}^n \sum_{k=1}^n \phi_{yj} \phi_{yk} \Gamma_{jx} \Gamma_{kx} h_j^*(\omega) h_k(\omega) S_b(\omega)$$

Where:

- $\phi_{yj}$  is eigenvector j for value y
- $\phi_{yk}$  is eigenvector k for value y
- $\Gamma_{jx}$  is the modal participation factor for mode j in the x direction
- $\Gamma_{kx}$  is the modal participation factor for mode k in the x direction
- $h_j(\omega)$  is the complex conjugate of the transfer function for mode j
- $h_k(\omega)$  is the transfer function for mode k
- $S_b(\omega)$  is the input acceleration power spectral density

The square of the response's standard deviation is the integral of the response PSD over the desired frequency band:

$$(\sigma_y^d)^2 = \int_{\omega_L}^{\omega_U} S(\omega) d\omega$$

The RMS response is equal to the standard deviation, since the mean is zero.

$$RMS = \sqrt{(\sigma_y^d)^2} = \sigma_y^d$$

Gaussian peak responses can be computed as follows:

$$\text{Peak} = \lambda \times \text{RMS}$$

# 5. Issues with traditional Random Analysis

## 5.1 Integration

As we have seen in section 3.3, the estimation of RMS results involves integration which is a computationally expensive process. Traditional solvers integrate each response, as a result their performance is directly related to the number of requested responses and the number of excitation frequencies.

## 5.2 Determination of excitation frequencies

Simcenter Nastran SOL 111 requires the user to define excitation frequencies. Below is an example acceleration PSD response of nodes on an electronic box computed by the SOL 111 random subcase, using:

- 198 excitation frequencies, linearly incremented between 10 and 1000 Hz (FREQ1)
- 125 frequencies spaced around the 67 natural frequencies and the end points at 10 and 1000 Hz (FREQ3).

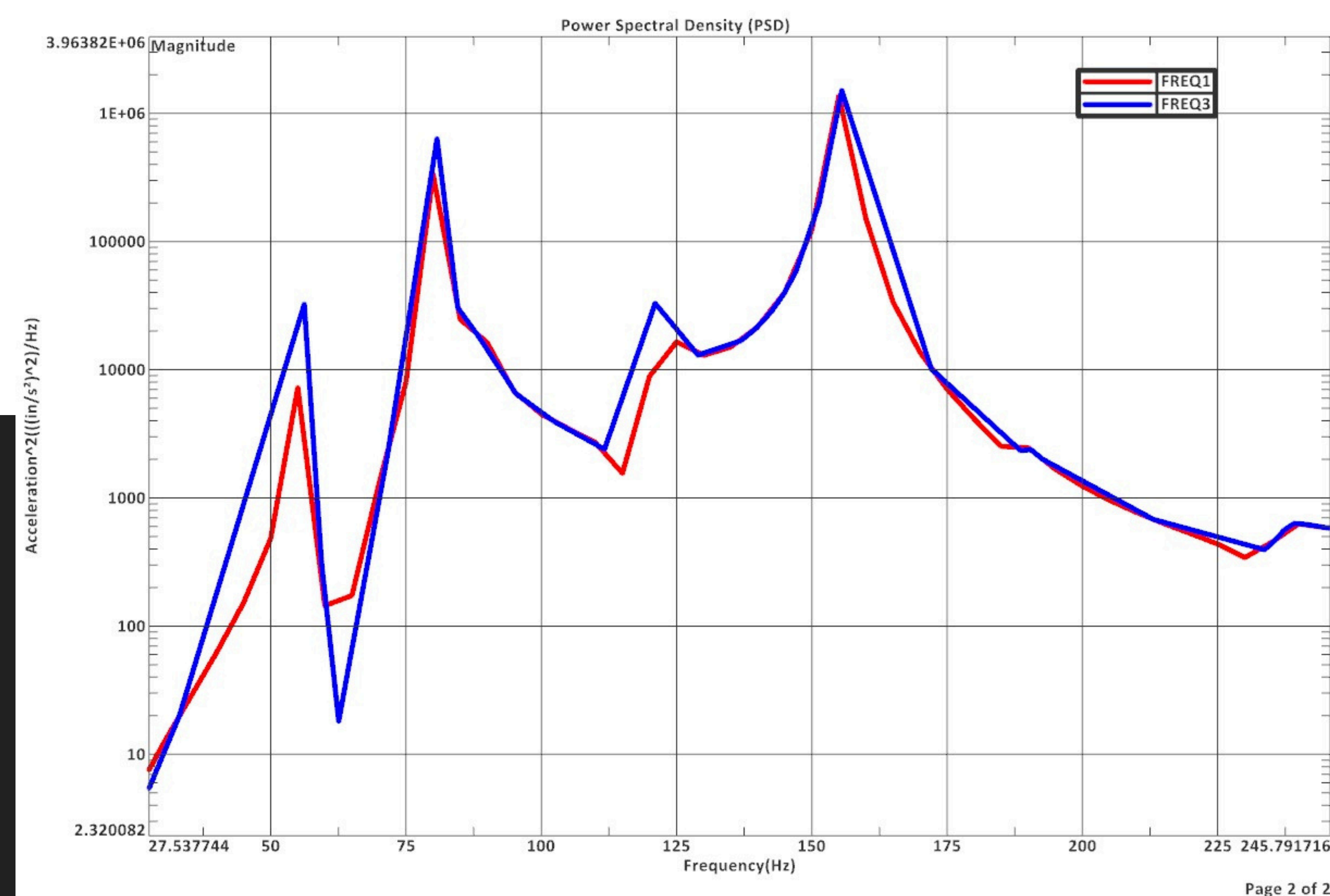

Figure 4: An example acceleration PSD response; Linearly spaced frequencies (FREQ1), Spaced around natural frequencies (FREQ3)

Even though there are more frequency points in the red curve (198) than in the blue one (125), it underestimates some peaks: There is a 16% difference in the RMS values of the 2 responses.

A user might be tempted to simply define a large number of excitation frequencies. While this does not significantly affect performance for small models, it can be very penalizing for large ones. A trial-and-error approach is therefore often used to determine the lowest acceptable number of excitation frequencies.

## 5.3 Estimating Derived Stress Quantities

### 5.3.1 Von Mises Stress

Most commercial finite element software estimate RMS quantities of Von Mises stress. However, Von Mises stresses don't have zero means since they're always positive, which implies they will not follow Gaussian distributions. Simulation engineers have little choice but to ignore this limitation and typically estimate the Peak Von Mises stress as  $\sigma_{vm, peak} = \lambda_{\sigma_{vm}}$ , RMS. For 99.73% confidence,  $\lambda = 3$ .

What error is incurred by this assumption? Is the assumption conservative, or does it dangerously underestimate the Peak values? To answer this question, we computed actual Von Mises stress distributions using Monte Carlo methods and estimated RMS and Peak values<sup>1</sup>.

#### 5.3.1.1 Monte Carlo Simulation

In the study, we chose a space antenna FEM consisting of 13,500 beam, shell and solid elements, as well as 8,300 nodes. The antenna main reflectors, inter-reflector structure, sub-reflector and struts are fabricated from Kevlar and carbon fiber composites. The central feed structure is metallic, and its elements were used for the Von Mises stress calculations, while the laminate elements were used for Tsai-Wu metrics described later.

We needed  $n$  random samples of Gaussian zero-mean Cartesian stresses  $(\sigma_x, \sigma_y, \sigma_{xy})$  which are consistent with the symmetric variance-covariance matrix of the Cartesian stresses  $[S]$  obtained from the random processor. We chose  $n = 5 \times 10^6$  for a balance of accuracy and computation time.

For each 2D element with isotropic material properties, the Von Mises stress was computed for all the  $(\sigma_x, \sigma_y, \sigma_{xy})$  samples, at both top and bottom. Statistics for the population of Von Mises stresses were then computed, such as mean and RMS. The cumulative distribution function was found, and the probability density function was obtained by numerical differentiation.

The Peak Von Mises stress corresponding to the chosen confidence was found by sorting the Von Mises samples in ascending order and choosing the sample corresponding to the confidence. The peak-to-RMS ratio was then calculated as follows:

$$ratio_{vm} = \frac{\sigma_{vm, peak}}{\sigma_{vm, rms}}$$

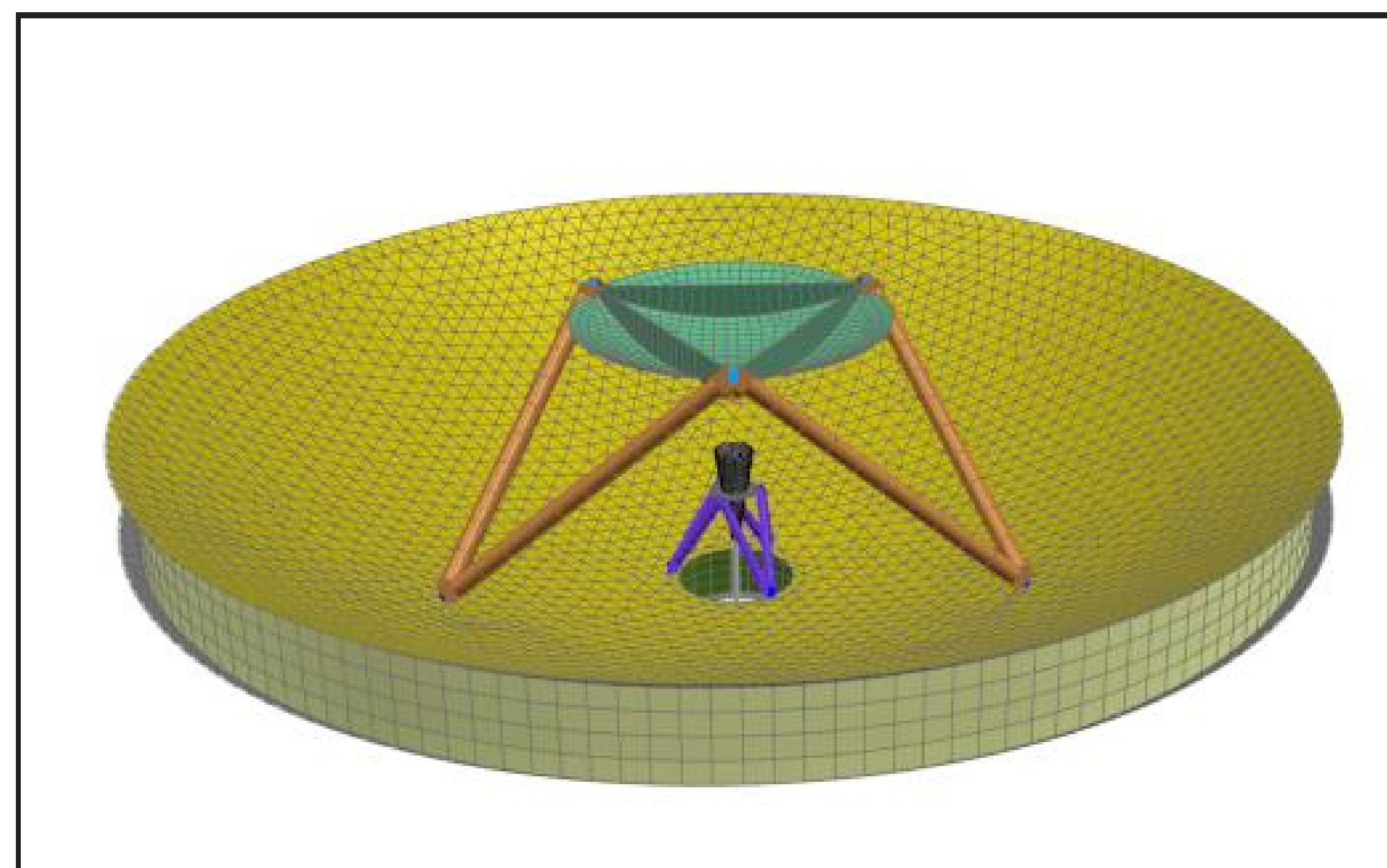

Figure 5 Space Antenna Model

The Monte Carlo simulation results for the 2D metallic elements in the antenna feed are presented in Table 2, including estimated minimum and maximum peak-to-RMS ratios and associated percent errors:

**Table 2 Von Mises stress results for antenna model.**

Confidence (%)	$\lambda$	Min Ratio	Error (%)	Max Ratio	Error (%)
99.00	2.5758	2.055	-25.32	2.574	-0.07
99.73	3	2.326	-28.99	2.999	-0.04
99.994	4	2.970	-34.66	-4.004	0.09
99.9999	5	3.614	-38.36	-5.105	2.05

The percent error is the error in assuming the Von Mises stress is Gaussian ( $\sigma_{vm,peak,Gaussian} = \lambda \sigma_{vm,rms}$ ) and is computed by comparing with Monte Carlo Simulation results ( $\sigma_{vm,peak}$ ) as follows:

$$\text{Error}(\%) = \frac{\sigma_{vm,peak} - \sigma_{vm,peak,Gaussian}}{\sigma_{vm,peak}} \times 100 = \frac{\text{ratio}_{vm} - \lambda}{\text{ratio}_{vm}} \times 100$$

For the industry standard confidence value of 99.73% ( $\lambda = 3$ ) the maximum error in the antenna model was found to be 28.99%. The error increases with the confidence level. The good news is that scaled RMS Von Mises Stresses ( $\lambda \sigma_{vm,rms}$ ) are higher than the more accurate Peak results ( $\sigma_{vm,peak}$ ), so that the industry practice is inherently conservative.

### 5.3.1.2 Segalman Method

The Segalman method is the industry standard approach of estimating random Von Mises stresses. It transforms the modal problem into a basis where the stress variables are uncorrelated, producing at most 5 independent, identically distributed Gaussian stress processes  $y$ , each with unit variance:

$$VM^2 = \sum_n y_n^2 D_n^2$$

The RMS Von Mises Stresses are:

$$\sigma_{VM\_RMS} = \sqrt{E[vm^2]} = \sqrt{\sum_n D_n^2}$$

The probability of the Von Mises stress exceeding a certain value  $Y$  is estimated using the single to quintuple integral:

$$P(VM^2 < Y) = \int_{Z(\{D\}, Y)} \prod \rho_r(y_r) \Pi dy_r$$

The Segalman method evaluates the above integral. Aside from computing the RMS Von Mises stress which is inaccurate as we have seen in the previous section, the estimation of this integral is computer intensive and results in performance problems for industrial models.

## 5.3.2 Other Derived Stress Quantities

Random solvers do not generally estimate minimum and maximum principal stresses, or maximum shear stresses. The same limitations apply for RMS estimates of these derived quantities, as do for Von Mises stresses.

## 5.4 Laminate failure metrics

Few if any commercial finite element software estimate RMS or Peak quantities of composite failure metrics. Simulation engineers typically convert RMS ply stress components to Peak using  $\lambda=3$ . However, since all the peak components are inherently positive, it's not possible to leverage interactive theories such as Tsai-Wu. But we can still investigate the type of error that would result if one were to take RMS Tsai-Wu failure metric results and scale them using  $\lambda$ .

We have done this using Monte Carlo Simulation, in a similar way to how Von Mises stresses were investigated.

### 5.4.1 Monte Carlo Simulation

A summary of results for the Tsai-Wu failure index FI is given in Table 3.

**Table 3 Tsai-Wu failure index results for antenna model**

Confidence (%)	$\lambda$	Min Ratio	Error (%)	Max Ratio	Error (%)
99.00	2.5758	3.276	21.37	3.835	32.84
99.73	3	4.220	28.91	5.210	42.42
99.994	4	6.984	42.73	9.265	56.83
99.9999	5	10.686	53.21	15.869	68.49

For the industry standard confidence value of 99.73% ( $\lambda = 3$ ), the maximum error in the antenna model was found to be 42.42%. Like for Von Mises stress, the error increases with the confidence level. Contrarily to Von Mises stress, scaling the RMS value of this failure index by  $\lambda$  would lead to an underestimation of the exact peak failure index, hence it is not a conservative practice.

## 5.5 Desktop locking

The historical trend is for FEMs to keep growing in size and more modes to be requested for improved accuracy. It's therefore not unusual for random base excitation solutions to take several hours to complete. This obviously shouldn't lock a user's desktop.

## 5.6 Estimating Peak values

The conversion from RMS to Peak results has been covered for both Gaussian and non-Gaussian results in sections 4.3 and 4.4. The need to constantly scale RMS results using the peak-to-RMS ratio  $\lambda$  is a major usability issue which users struggle with in the absence of any alternative.

## 5.7 Requesting multiple result types

The relative complexity of random simulations is such that users typically need some form of validation. This can include:

- Requesting the response PSD at the enforced motion location and comparing it to the input PSD
- Examining components of the stress tensor to validate failure metric results.
- Requesting acceleration responses to compare with historical data.

Fastener analysis may rely on the extraction of element and or grid point forces.

Some software requires the user to submit a different solver run for each desired result type. The limitations of this architecture are apparent when several iterations are performed on large models with many structural connections.

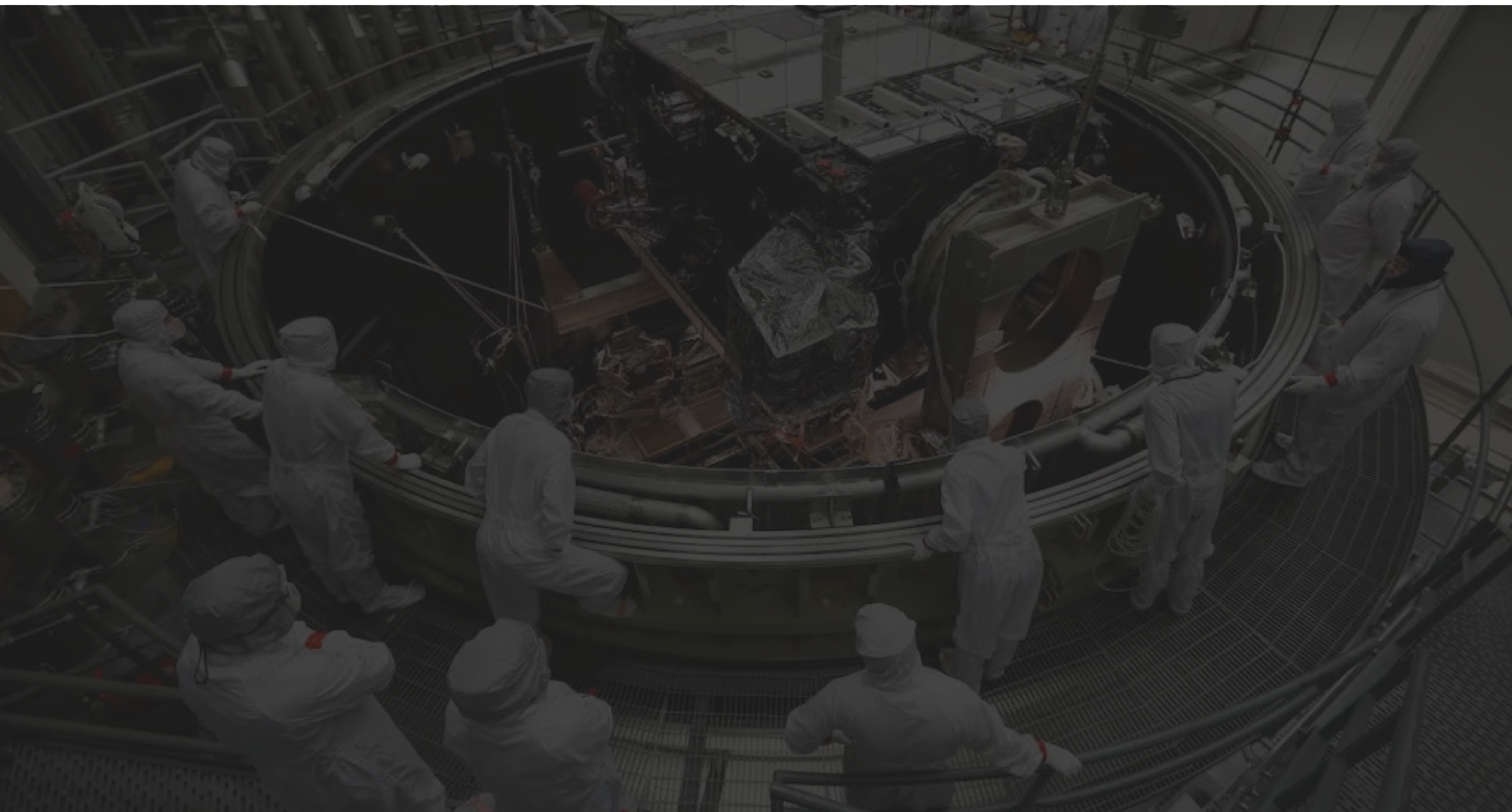

# 6. SAToolkit Random Processor

To address the issues identified in section 4, Maya's SAToolkit offers a dedicated Random Processor. This processor utilizes an efficient and accurate modal approach to evaluate the dynamic response of a structure subjected to a random base acceleration power spectral density (PSD) function.

## 6.1 Random Processor Solution

The Random Processor references a Simcenter or MSC Nastran SOL 103 result file, from which it extracts the following data:

- Modal data: eigenvalues, eigenvectors, and modal participation factors.
- Residual vectors (optional).
- Failure data for laminates: ply failure theories and material stress and strain limits.

### 6.1.1 Solver

The solver uses advanced integration algorithms to produce any combination of specified output in a single analysis and implements multithreading to enhance performance. It automatically determines the required excitation frequencies on a result-by-result basis, so you are not responsible for defining the right number of spectral lines.

The Random Processor consumes all selected normal modes from the solved modal model. It queries the user-specified modal damping entered as an amplification factor  $Q$ . All other forms of damping are ignored.

### 6.1.2 Specifying the PSD excitation function

The Random Processor computes the following contour results:

- Peak or RMS acceleration, displacement, velocity, multipoint constraint (MPC) force, single-point constraint (SPC) force, and grid point force. The software automatically computes phase-consistent translational and rotational magnitudes for the above, except grid point force.
- Peak or RMS stress, strain, and force. The software automatically computes Von Mises stress and strain for both homogenous and laminate elements. You can also specify how the Random Processor computes principal stresses and strains using an approximate (faster) or a precise (slower) method.
- Peak and RMS failure indices, strength ratios (laminates only), and margins of safety.
- Number of positive zero crossings responses for acceleration, displacement, velocity, MPC force SPC force, stress, strain, and force

The Random Processor computes the following function results:

- Power spectral density XY functions for acceleration, displacement, velocity, MPC force, SPC force, stress, and strain.

### 6.1.3.1 Peak Contour Results

Peak results account for the user-defined confidence level, which is typically 99.73% or 3-sigma. You are not required to post-process the results by multiplying the root mean squared (RMS) results by 3, as you do for Nastran Solution 111 or 108. The solver uses advanced methods to accurately determine the Peak value for derived results that do not follow a Gaussian distribution, such as Von Mises stresses or Tsai-Wu failure indices.

### 6.1.3.2 RMS Contour Results

For basic results such as components of acceleration or stress tensor components, RMS results computed by the Random Processor are identical to Peak results defined with a confidence value of 68.27% ( $\lambda=1$ ). This is not true for derived results like Von Mises stress. In order to compare Random Processor derived results with those produced by the Random event and Nastran SOL 111, you must request RMS results. RMS Von Mises stress results are computed by the Random Processor using the Segalman method and compare well with Von Mises stresses from the other 2 solvers.

### 6.1.3.3 Pre and Post-Processors

Nastran SOL 103 solutions can be prepared in Simcenter 3D Engineering Desktop as well as in Simcenter FEMAP. The same products can be used to display contour and PSD XY Function results created in op2, binary universal (.bun) and FEMAP neutral (.NEU) formats.

## 6.1.4 Running from a command line

You can run the Random Processor from a command line, leveraging other Windows or Linux servers at your disposal.

## 6.2 Benchmark

Two solvers were compared in terms of performance and accuracy for a random base excitation simulation:

- SAToolkit V9 Random Processor
- Simcenter Nastran SOL 111 with random subcase

The compared results include:

- Acceleration
- Stress tensor components (CQUAD4, TET10, PCOMP)
- Von Mises stress (CQUAD4, TET10)
- Force (CELAS2, CBUSH)

The benchmark was performed with the spacecraft model shown in Figure 7, which contains:

- 161,672 nodes
- 130,562 elements broken down as follows:
  - 1D: CBUSH, CELAS, CBEAM and CBAR
  - 2D: CQUAD isotropic shells and laminate
  - 3D: TET10

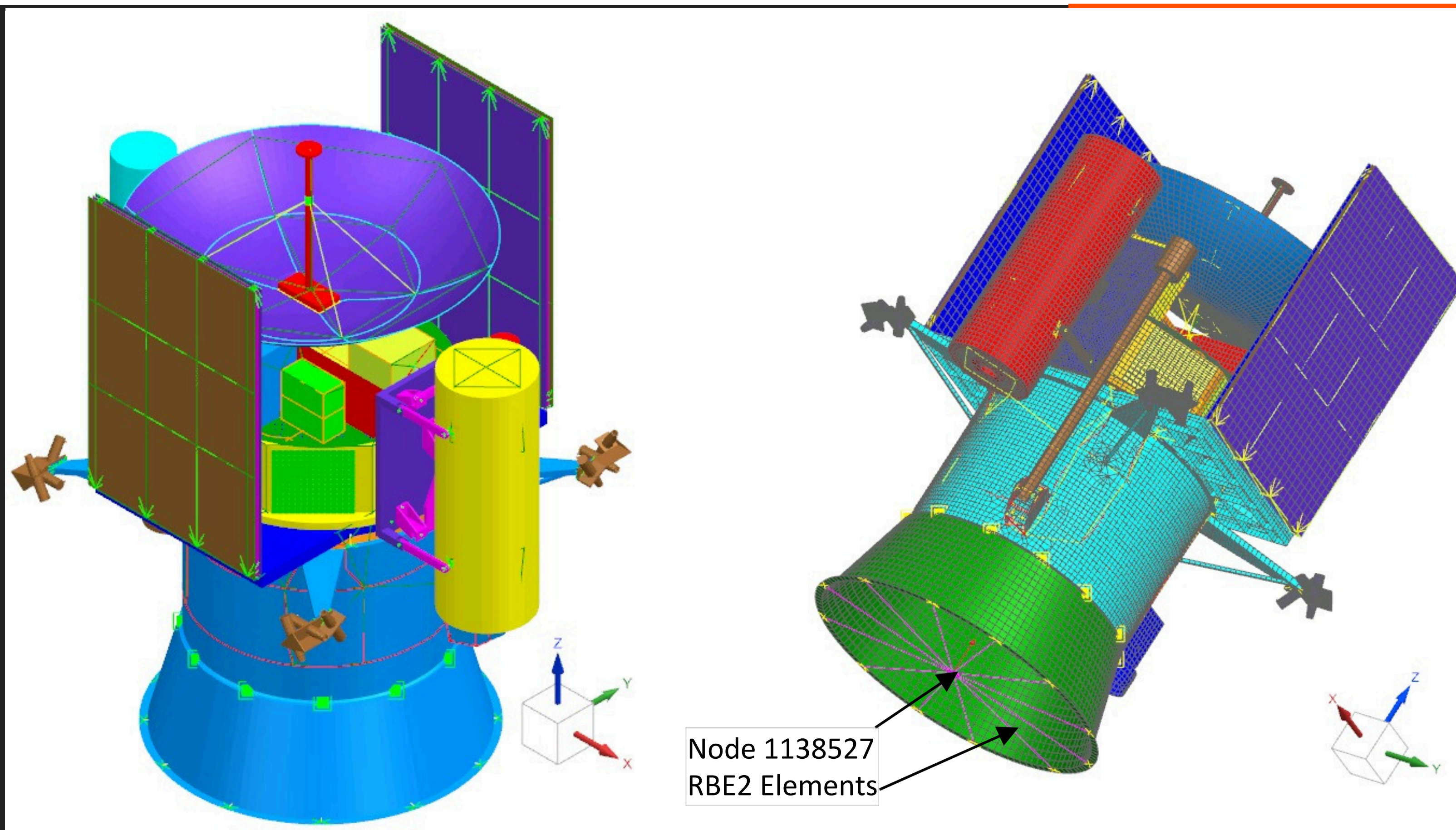

**Figure 6: Spacecraft model, base acceleration was applied at node 1138527.**

A base acceleration was applied in the Z direction at node 1138527. This enforced location node was connected by 12 RBE2 elements to the conical launch adaptor. The base acceleration was defined by the power spectral density function of Figure 7.

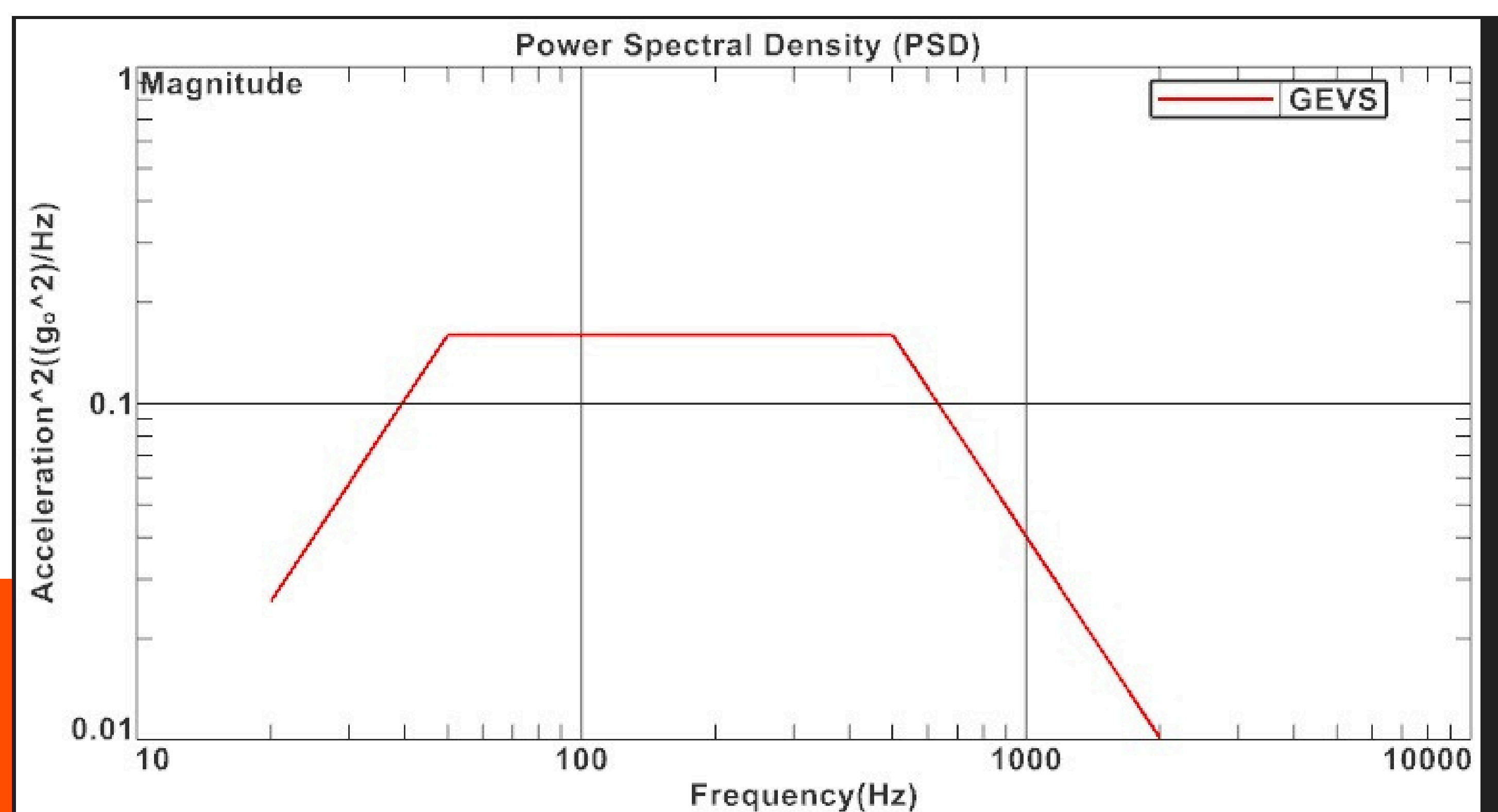

**Figure 7: PSD input for base acceleration.**

The modal basis consisted of the first 150 constrained modes, the effective masses of which are shown in Table 4 below.

Mode	Freq (Hz)	Mx	My	Mz	Mx (%)	My (%)	Mz (%)
1	23.369	6.32E+00	1.16E+00	9.72E-03	1.1%	0.2%	0.0%
2	24.691	1.57E+00	7.01E+00	1.39E-04	0.3%	1.2%	0.0%
3	31.928	4.17E+01	7.54E+01	2.95E-01	7.0%	12.7%	0.0%
4	32.719	5.40E+01	4.77E+01	2.51E-01	9.1%	8.1%	0.0%
5	34.203	7.44E+00	2.67E+00	5.06E-02	1.3%	0.5%	0.0%
6	36.487	1.08E+00	3.76E+01	1.73E+00	0.2%	6.3%	0.3%
7	42.188	2.62E+02	7.64E+00	6.40E-02	44.3%	1.3%	0.0%
8	46.025	1.50E+01	1.81E+02	2.17E-01	2.5%	30.6%	0.0%
9	51.699	4.36E-01	9.19E+01	2.86E-02	0.1%	15.5%	0.0%
10	53.581	6.71E-02	2.33E-03	8.15E-03	0.0%	0.0%	0.0%
11	54.211	3.40E+00	1.04E-01	1.36E-02	0.6%	0.0%	0.0%
12	62.666	1.44E+01	2.51E-01	1.34E-02	2.4%	0.0%	0.0%
13	74.049	1.10E+01	1.24E-01	9.40E+00	1.9%	0.0%	1.6%
14	75.989	1.75E+00	1.48E-01	4.40E+00	0.3%	0.0%	0.7%
15	76.138	1.24E+00	5.84E-03	8.84E-01	0.2%	0.0%	0.1%
16	76.689	8.93E-02	6.45E-02	2.27E-02	0.0%	0.0%	0.0%
17	77.681	1.38E+01	2.65E-02	2.31E+01	2.3%	0.0%	3.9%
18	83.697	1.40E+00	1.05E+00	8.51E-01	0.2%	0.2%	0.1%
19	84.104	2.54E+00	2.16E+00	1.66E+00	0.4%	0.4%	0.3%
20	84.694	4.23E-03	5.74E-03	3.16E-03	0.0%	0.0%	0.0%
21	84.904	3.04E-03	4.00E-03	5.57E-02	0.0%	0.0%	0.0%
22	85.015	1.72E-02	6.22E-02	2.09E-02	0.0%	0.0%	0.0%
23	91.783	1.04E+01	6.18E-01	3.24E+02	1.8%	0.1%	54.8%
24	96.190	4.98E-02	1.70E-01	3.44E-01	0.0%	0.0%	0.1%
25	96.765	2.18E+01	4.92E+00	1.41E+01	3.7%	0.8%	2.4%
26	100.463	1.88E+01	2.08E+00	4.84E+00	3.2%	0.4%	0.8%
27	102.622	2.66E+00	7.80E+00	8.24E+00	0.4%	1.3%	1.4%
28	105.604	9.61E+00	8.32E-01	6.15E+00	1.6%	0.1%	1.0%
29	106.500	6.99E-03	4.02E-01	6.15E+00	0.0%	0.1%	1.0%
30	108.584	8.89E+00	6.98E-01	4.28E+01	1.5%	0.1%	7.2%
31	110.875	2.42E+00	2.21E-01	3.02E+01	0.4%	0.0%	5.1%
32	113.187	2.85E+00	3.57E+00	2.93E+01	0.5%	0.6%	5.0%
...	...	...	...	...	...	...	...
144	390.218	2.44E-03	6.01E-02	5.47E-02	0.0%	0.0%	0.0%
145	392.980	1.66E-02	3.05E-01	3.39E-02	0.0%	0.1%	0.0%
146	394.751	3.57E-02	3.09E-03	8.28E-02	0.0%	0.0%	0.0%
147	396.025	1.29E-03	9.94E-05	3.17E-02	0.0%	0.0%	0.0%
148	400.434	6.49E-04	2.04E-02	5.62E-02	0.0%	0.0%	0.0%
149	404.155	2.38E-01	3.96E-02	9.86E-01	0.0%	0.0%	0.2%
150	407.053	9.59E-02	6.97E-02	8.03E-02	0.0%	0.0%	0.0%
<b>Total</b>		<b>580.682</b>	<b>580.518</b>	<b>575.263</b>	<b>98.1%</b>	<b>98.1%</b>	<b>97.2%</b>

The Random Processor computes the following function results:

- Power spectral density XY functions for acceleration, displacement, velocity, MPC force, SPC force, stress, and strain.

## 6.2.1 Solution Setup

The spacecraft FEM was created using Simcenter 3D Desktop version 2021.1. Simcenter Nastran 2021.1 was used for solving SOL 111 Modal Frequency Response; Simcenter Nastran 2021.2 was to solve SOL 103 used by SAToolkit V9 Random Processor.

### 6.2.1.1 Residual Vectors

The Nastran SOL 111 solution included the definition of inertial load residual vectors as per the following card:

```
RESVEC (NOAPPL, NORVDO, NORVEL, INRL0D, NODAMP, NODYNRSE) = YES
```

The Nastran SOL 103 solution used by SAToolkit included the definition of inertial load residual vectors as per the following card:

```
RESVEC (NOAPPL, NORVDO, INRL0D, NORVEL, NODAMP) =YES
```

Since the benchmark model's cumulative effective masses are quite high in all translational directions, the consideration or not of residual vectors probably has little effect on the result comparisons.

### 6.2.1.2 Excitation Frequencies

#### 6.2.1.2.1 Random Processor

The Random Processor automatically determines the required excitation frequencies, by result type. There is no user action.

#### 6.2.1.2.2 Nastran SOL 111

In the Nastran SOL 111 solution, excitation frequencies were defined using the FREQ3 card. This card includes all natural frequencies, and the user specifies the number of frequencies, NEF, between natural frequencies.

Since increasing NEF improves accuracy at the expense of performance, we followed a trial-and-error approach to determine the lowest acceptable values. First, we selected randomly dispersed nodes in different locations of the model and computed RMS values of acceleration using a high number of intermediate frequencies. Then, we reduced the number of frequencies until the results started to diverge. Convergence can be affected by the choice and number of sample nodes. The following steps were performed:

1. 150 nodes were selected out of the model's 161,672 nodes.
2. NEF was initially set to 1000.
3. RMS translational accelerations were extracted.
4. A 5% convergence criterion was used. NEF values were reduced until the convergence failed. This occurred at NEF = 40.
5. These intermediate frequency values were used in the benchmark. The final FREQ3 card used is shown below for reference.

\$FREQ3	SID	F1	F2	TYPE	NEF	CLUSTER
FREQ3	101	20	2000	LINEAR	40	1

### 6.2.1.3 Stress Recovery

In all Nastran solutions, stresses were requested at the element centroids only:

```
STRESS (PLOT, REAL, VONMISES, CENTER) = 25
```

However, for solid elements Nastran recovers the stresses at the corner nodes as well in the op2 file, regardless of this setting. Hence in this benchmark, Nastran SOL 111 random subcase computed corner stresses for the solid elements of the spacecraft FEM. The Random Processor can compute centroidal or corner node stresses, not both: It was instructed to compute corner node results for consistency, at the expense of performance since this was not required for the shell elements.

### 6.2.1.4 Modal Damping

Constant modal viscous damping of 2% critical ( $Q = 25$ ) was applied to all modes in both SATK and Simcenter Nastran SOL 111. No other sources of damping were considered.

## 6.2.2 Machine

All solutions were performed on a Windows 10 machine with 8 x 3.80 GHz cores, over 2 TB of available disk space and 64 GB RAM.

## 6.3 Improving Efficiency

The SAToolkit Random Processor provides unprecedented efficiency due to the best-in-class performance of its solver as well as its streamlined and intuitive workflows, including the ability to process multiple result types in a single solve, automatic computation of Peak results that correspond to a user-defined confidence, automatic computation of failure metrics, and the option to solve in batch mode.

The Random Processor computes the following function results:

- Power spectral density XY functions for acceleration, displacement, velocity, MPC force, SPC force, stress, and strain.

### 6.3.1 Solver Performance

The current benchmark illustrates the significant performance gain of the Random Processor compared to Nastran Solution 111. As shown in Table 5, it's 2,999X faster than Nastran SOL 111 at computing accelerations for about 160,000 nodes. At computing Von Mises and tensor stresses for about 110,000 elements, it's over 11,000X faster than Nastran. It should be noted that Nastran SOL 111 required over 2 TB of scratch space to complete the solution.

**Table 5 Spacecraft benchmark solution time comparison**

Elapsed time – seconds (Normalized with respect to Random Processor)		
Output Request(s)	Random Processor	Nastran SOL 111 <sup>8</sup>
<b>Acceleration</b> 161,672 nodes	8 (1)	23,990 (2,999)
<b>Force</b> 445 1D elements	2 (1)	132 (66)
<b>Stress<sup>1</sup></b> 110,274 elements	9 <sup>5</sup> (1)	99,230 <sup>6</sup> (11,026)
<b>Acceleration, Stress<sup>1,6</sup> and Force</b> 110,274 elements	15 <sup>5</sup> (1)	123,352 <sup>6</sup> (8,223)
<b>Acceleration, Stress<sup>1</sup>, Force, Principal Stresses, Failure Index, Margin of Safety, and laminate Strength Ratio</b>	185 s <sup>3,5</sup>	n/a <sup>7</sup>

1. Tensor components and Von Mises stress
2. Unused
3. Principal Stress Method set to Approximate
4. Unused
5. Center and corner stresses requested for all elements
6. Center stresses for 2D elements; corner stresses for 3D elements
7. Nastran SOL 111 does not compute principal stresses, failure indices, margins of safety and laminate metrics
8. This is the time for the restarted random subcase and excludes the SOL 103 solve time

The Random Processor computes the following function results:

- Power spectral density XY functions for acceleration, displacement, velocity, MPC force, SPC force, stress, and strain.

### **6.3.1.1 Von Mises Stress**

It's also clear that the advanced Random Processor Von Mises stress estimation algorithms are particularly performant compared to the other solvers. This is a game-changing feature since it allows for very large models to be solved, models which previously would not have been considered for a random analysis. An implication is that time-consuming FEM simplification and abstraction efforts can be reduced or eliminated, thereby saving manpower and reducing calendar time.

### **6.3.1.2 Integration**

The Random Processor's outstanding performance relies on an advanced integration approach, which contrarily to traditional solvers operates on a subset of the output requests.

## **6.3.2 Workflow**

Solution time is an important consideration, however it's not the only one. The time users spend preparing the solution and processing results, and the ability to work in parallel, are key considerations.

### **6.3.2.1 Output Requests**

Like Nastran, the Random Processor allows the user to request multiple result types (accelerations, forces, etc.) in the same solution. Unlike Nastran however, a single solution can produce both contour and XY plot results.

### **6.3.2.2 Peak results**

Nastran produces RMS results, which are typically converted to Peak results by the user who manually scales the results by a factor of 3. Whereas this workflow is deeply entrenched in industry, it's now completely unnecessary.

### **6.3.2.3 Batch solutions**

The current benchmark uses a medium-sized model with a medium-sized modal basis. It's not uncommon for FEMs to contain more than 1 million elements, and for several hundred modes to be retained. Typically, three axes of excitation are required. This can imply several hours of computation. The ability to run single or multiple solutions in batch mode on a local or remote server is therefore critical.

### **6.3.2.4 Automatic Failure Metrics**

In most FE projects, calculating the stresses is not a goal. Rather, engineers validate a design by comparing simulation results to strength or strain limits. The Random Processor can extract strengths from Simcenter 3D isotropic and orthotropic materials. These are stored in the results file of the Nastran SOL 103 simulation. Users can then request failure metrics for homogeneous elements (failure index, margin of safety), as well as laminate failure metrics for composite elements (failure index, strength ratio, margin of safety).

## 6.4 Improving Accuracy

For basic results like components of acceleration, stress tensor and element forces, section 6.4.1 shows that the Random Processor compares very well with Nastran SOL 111.

Section 6.4.2.2 shows that, for derived results like Von Mises stress, the Random Processor provides enhanced accuracy as its Peak results are consistent with the user-defined confidence. The Random Processor produces other derived results which are unavailable when using Nastran SOL 111.

For the purpose of validation, RMS Von Mises stresses can be requested and compared with the Nastran RMS stresses. Section 6.4.2.1 shows an excellent correlation.

Users can therefore safely migrate to the Random Processor and benefit from its superior accuracy.

### 6.4.1 Basic Results

The next 3 sections compare the RMS values of basic results produced by the Random Processor and Simcenter Nastran SOL 111 random subcase. Since the differences increase as the relative magnitudes of the results decrease, for reasons that include rounding off, the differences are determined against percent ranges of the maximum result value.

Table 6 summarizes the maximum differences between Random Processor and SOL 111 for results greater than 50% of maximum value.

**Table 5 Spacecraft benchmark solution time comparison**

Result component (RMS)	Nastran SOL 111	
	Max <sup>1</sup>	Avg <sup>2</sup>
Acceleration (X, Y or Z)	0.02%	0.16%
Element Force - CBUSH (NXX, NYY or NZZ)	0.43%	0.90%
Stress Tensor (XX, YY or XY)	0.48%	0.33%

#### Notes

1. Maximum difference for all results greater than 50% of maximum value
2. Average over all results

The RMS acceleration, force and stress results compare extremely very well between the Random Processor and Simcenter Nastran SOL 111 random subcase.

### 6.4.1.1 RMS Accelerations

Table 7 shows the differences between Random Processor and Nastran SOL 111 for each component of RMS acceleration, on the roughly 162,000 nodes of the Spacecraft FEM.

**Table 5 Spacecraft benchmark solution time comparison**

Acceleration Range (% of Max)	Nastran SOL 111					
	X		Y		Z	
	Max	Avg	Max	Avg	Max	Avg
50% - 100%	0.001%		N/A	N/A	0.02%	
10% - 100%	0.02%		2.5%		0.35%	
1% - 100%	8.7%		4.8%		0.77%	
All	10.0%	0.05%	4.8%	0.13%	0.77%	0.16%

Figure 8 shows the contour plots of the Z component of RMS acceleration (Left: Random Processor; Right: Nastran SOL 111)

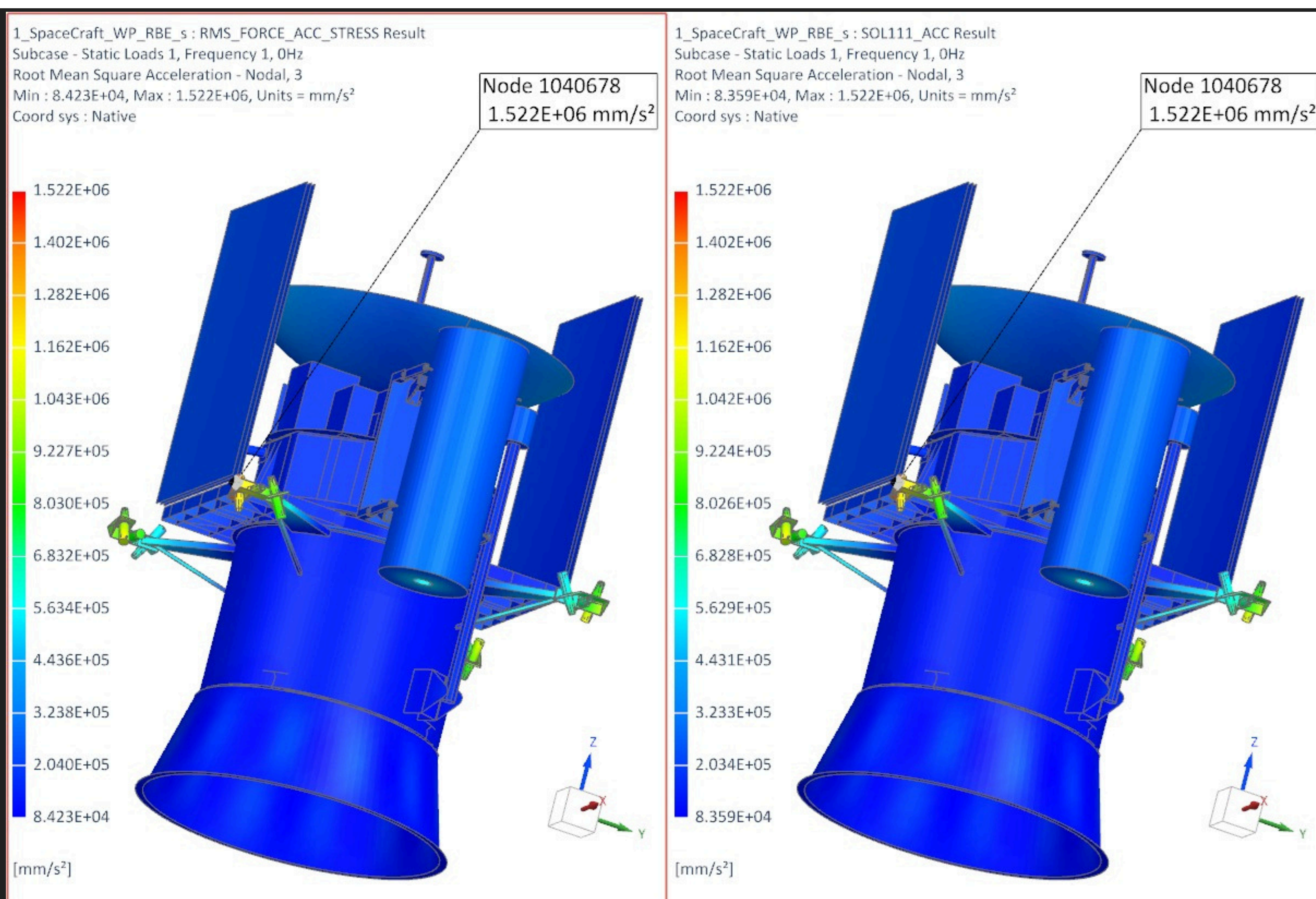

**Figure 8: RMS Z-Acceleration Contours**

### 6.4.1.2 RMS CBUSH Forces

Table 9 shows the differences between Random Processor and Nastran SOL 111 for each component of RMS element force.

**Table 9 RMS Forces, Compare Random Processor to Nastran SOL 111**

Force Range (% of Max)	Nastran SOL 111					
	NXX		NYY		NZZ	
	Max	Avg	Max	Avg	Max	Avg
50% - 100%	0.05%		0.39%		0.43%	
10% - 100%	0.84%		0.51%		0.67%	
1% - 100%	1.83%		12.4%		0.82%	
All	1.83%	0.26%	12.4%	0.90%	0.82%	0.17%

Figure 9 shows the contour plots of the Z component of Element Force (Left: Random Processor; Right: Nastran SOL 111)

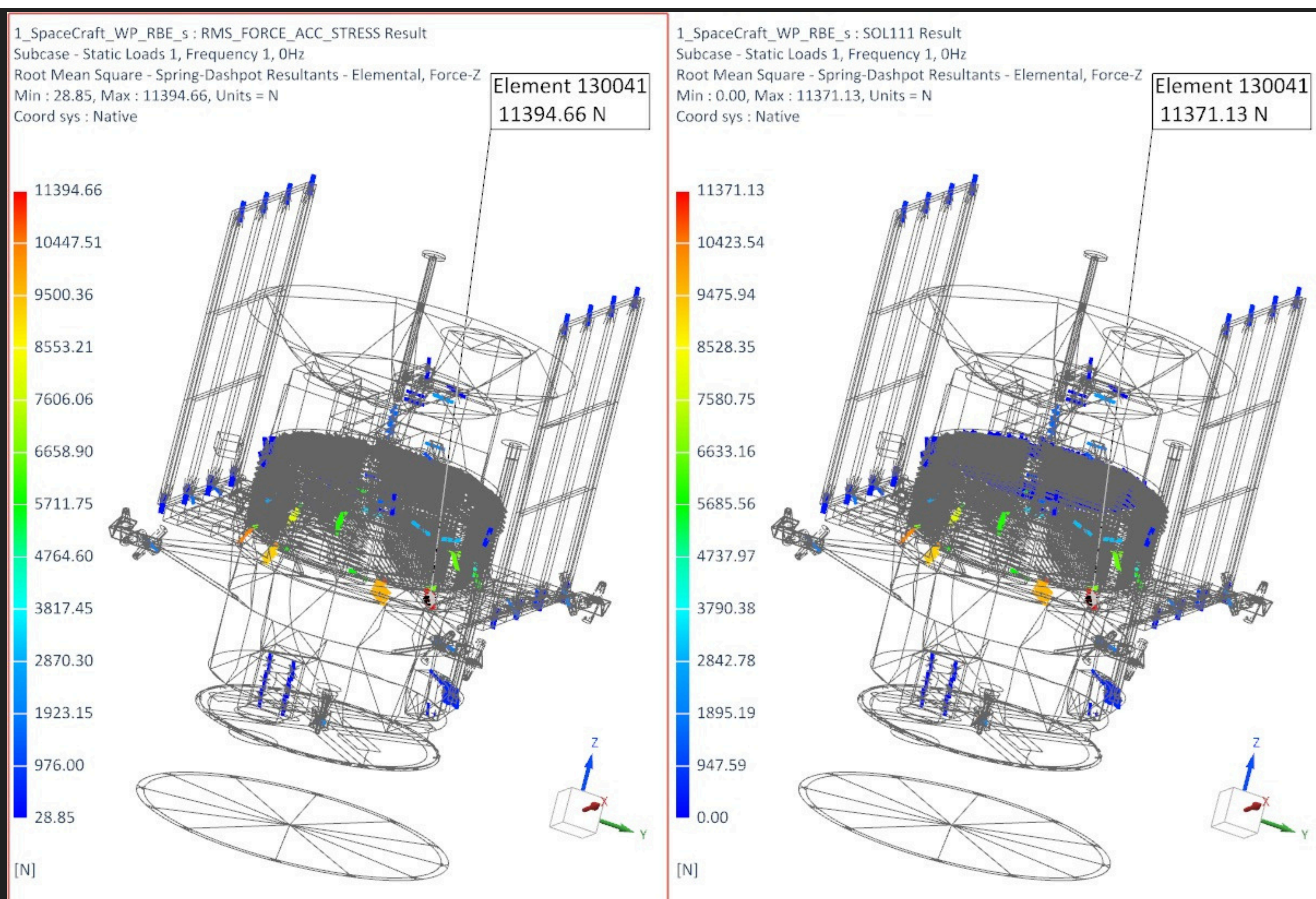

**Figure 9 RMS Z-Force Contours**

### 6.4.1.3 RMS Stresses

Table 10 shows the differences between the Random Processor and Nastran SOL 111, for XX, YY and XY components of RMS stress tensor.

**Table 10 RMS Stresses, Compare Random Processor to Nastran SOL 111**

Stress Range (% of Max)	Nastran SOL 111					
	XX		YY		XY	
	Max	Avg	Max	Avg	Max	Avg
50% - 100%	0.13%		0.42%		0.48%	
10% - 100%	15.1%		2.5%		18.8%	
1% - 100%	28.0%		26.6%		29.7%	
All	34.8%	0.31%	41.3%	0.33%	29.7%	0.28%

Figure 10 shows the contour plots of the XX component of Stress (Left: Random Processor; Right: Nastran SOL 111)

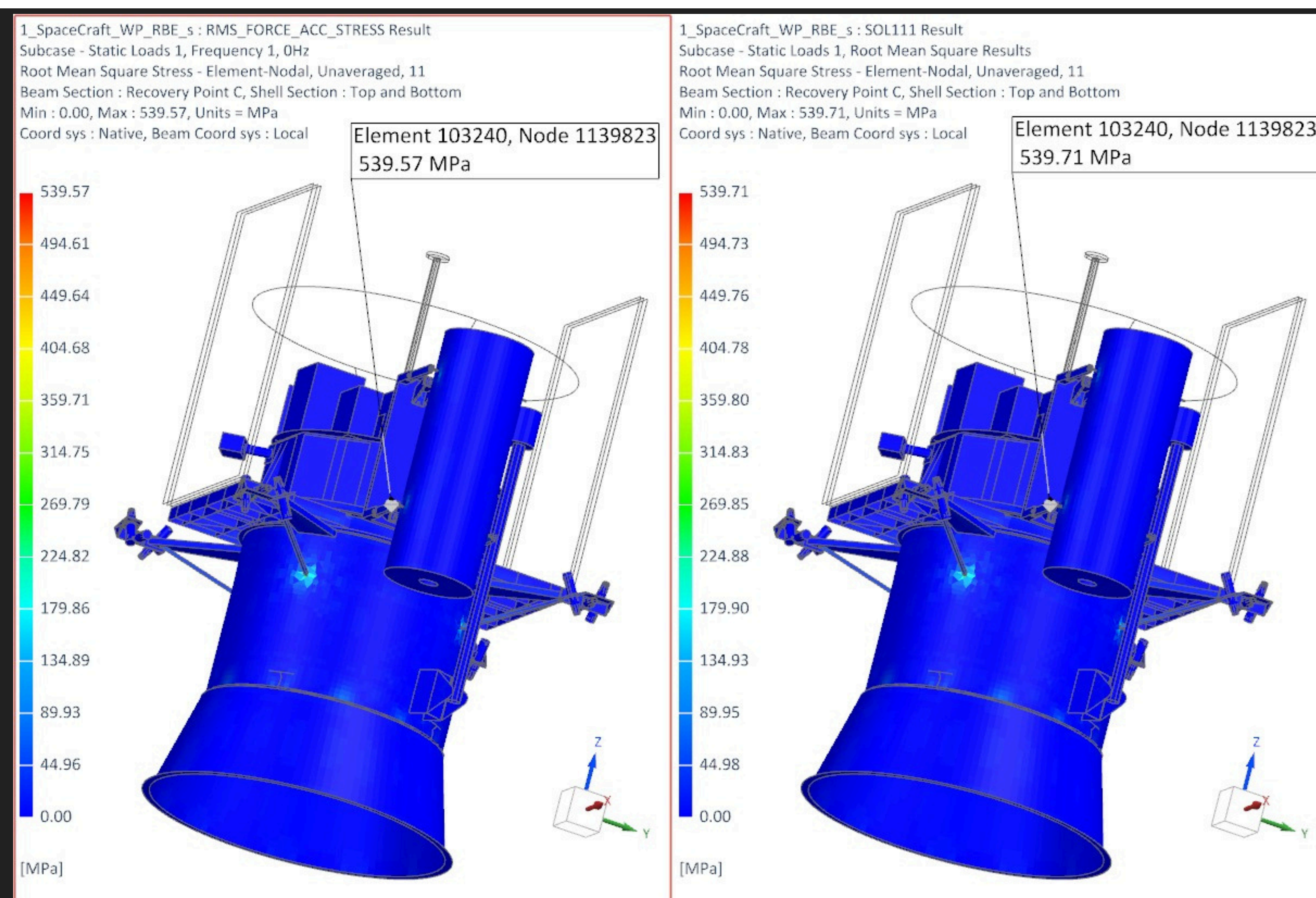

**Figure 10 RMS XX Stress Contours**

## 6.4.2 Derived Results

We've seen that derived results like displacement magnitude, Von Mises stress and Tsai-Wu failure index do not have zero-mean Gaussian distributions and hence their peak to RMS ratios are unknown. Therefore, scaling RMS Von Mises stress by 3 does not yield the same confidence as scaling the X component of stress by the same factor. That's why the Peak Von Mises stress results of the Random Processor are so important: Firstly there is no need to scale, and secondly the confidence of all results, basic and derived, is consistent.

### 6.4.2.1 RMS Von Mises Stress

It's possible to request RMS results from the Random Processor for validation purposes. Here we compare the RMS Von Mises stresses computed by Random Processor with those computed by Nastran SOL 111, for the benchmark Spacecraft FEM. When the Von Mises stress is above 50% of the maximum value, the errors are within 0.03%; The average error over all elements is 0.26%.

**Table 11 RMS Von Mises Stresses, Compare Random Processor and Nastran SOL 111**

Von Mises Stress Range (% of Max)	Nastran SOL 111	
	Max	Avg
50% - 100%	0.03%	
10% - 100%	0.48%	
1% - 100%	18.85%	
All	20.98%	0.26%

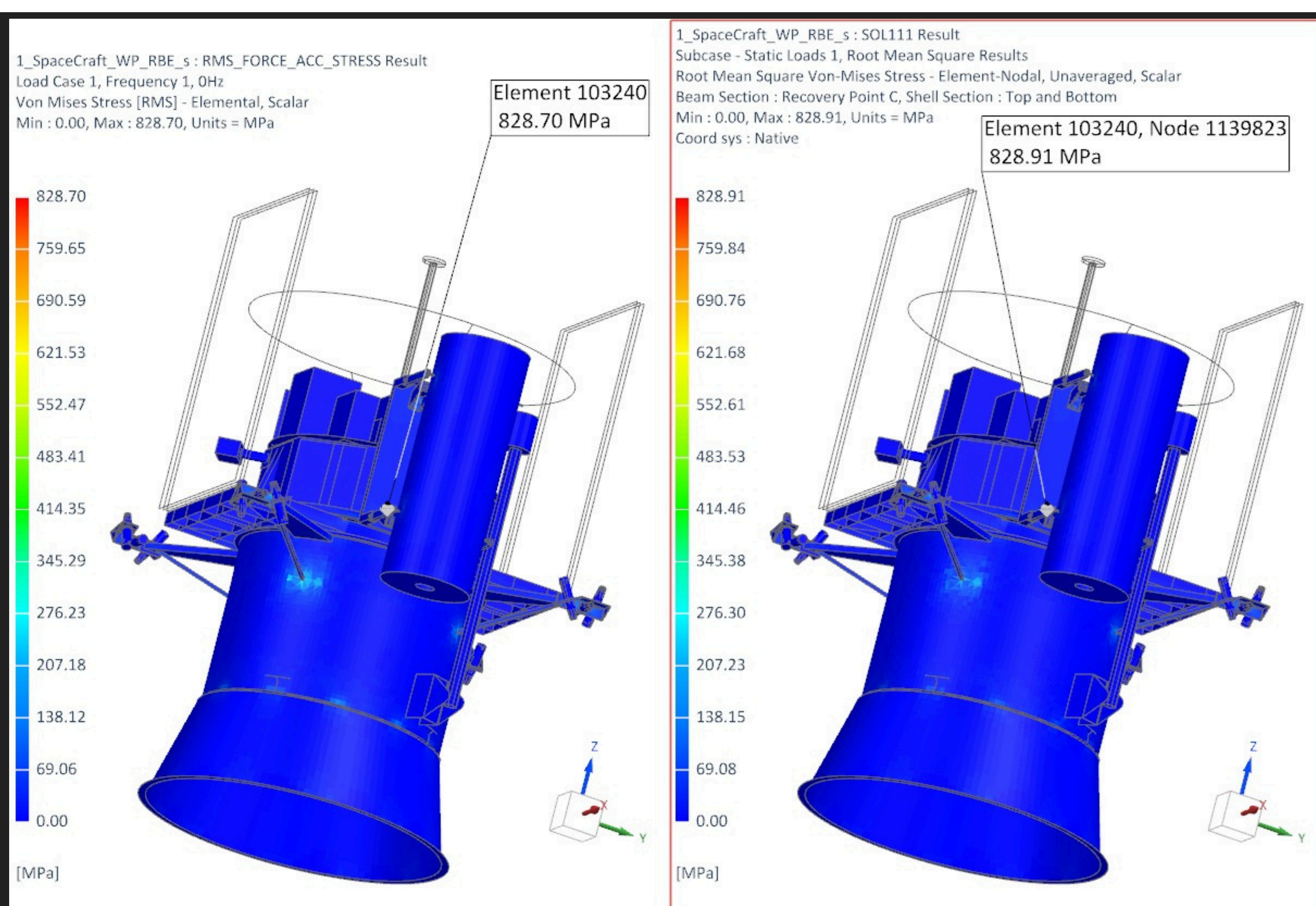

**Figure 11: RMS Von Mises Stress Contours**

Figure 11 shows the RMS Von Mises stress contours on the benchmark spacecraft FEM. In the left viewport, Random Processor; In the right viewport, Nastran SOL 111.

### 6.4.2.2 Peak Von Mises Stress

One of the principal advantages of the Random Processor is the accurate computation of Peak Von Mises stresses that correspond to the desired confidence level, and that match stresses obtained using Monte Carlo methods described in section 5.3.1.1. Table 12 compares the Peak Von Mises stress, corresponding to 99.73% confidence, with the RMS Von Mises stress multiplied by a peak-to-RMS ratio  $\lambda = 3$ .

For the upper range, the error is small. However, for values below 50% of the maximum Von Mises stress, the 3 X RMS results errors can be as high as about 25%. This is similar to the error found with the antenna model, ie 28.99%.

**Table 12 Von Mises Stress, Difference between Peak and 3 X RMS**

Peak Von Mises Stress Range (% of Max)	RMS Von Mises Stress X 3	
	Max	Avg
50% - 100%	0.42%	
10% - 100%	15.5%	
1% - 100%	25.3%	
All	25.3%	3.9%

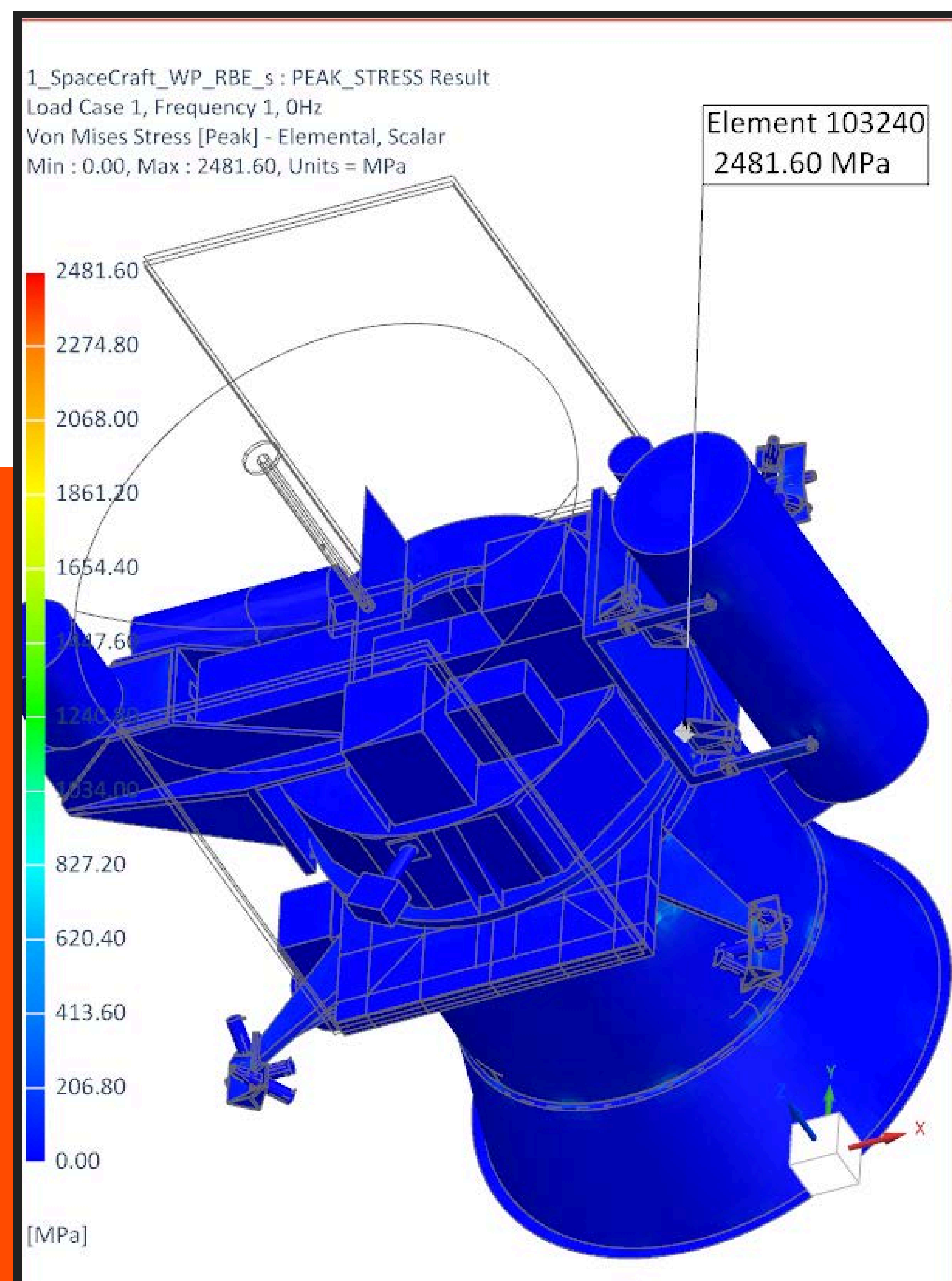

**Figure 12: Peak Von Mises Stress on Spacecraft FEM**

### 6.4.2.3 Others

The Random Processor can compute additional derived responses, including nodal result magnitudes, maximum shear stress, maximum and minimum principal stresses, ply and bond failure index, strength ratio and margin of safety, as well as failure index and margin of safety for homogeneous elements. Some of these are listed in Table 13.

**Table 13 Derived results specific to the Random Processor**

Acceleration (mm/s <sup>2</sup> )				
	Component	Node ID	Nastran SOL 111	Random Processor
	Magnitude	1059403	n/a	1.65E+06
Stress (MPa)				
Element Type	Component	Element ID	Nastran SOL 111	Random Processor
<b>QUAD4 laminate</b>	MAX Shear	4255	n/a	10.0
	Ply Failure Index	51105	n/a	0.0103
	Bond Failure Index	52398	n/a	0.0003
	Ply Strength Ratio	51105	n/a	14.0
	Bond Strength Ratio	51013	n/a	79.35
	MOS (Bond)	51105	n/a	8.9
<b>QUAD4 isotropic</b>	MAX Shear	8346	n/a	100.29
	Min Principal (fast)	8346	n/a	-130
	Min Principal (precise)	8346	n/a	-130
	Max Principal (fast)	8346	n/a	127
	Max Principal (precise)	8346	n/a	130
	Margin of Safety	8346	n/a	-0.15
	Failure Index	8346	n/a	1.18
<b>TET10</b>	Min Principal (fast)	94452	n/a	-85
	Min Principal (precise)	94452	n/a	-83
	Max Principal (fast)	94452	n/a	85
	Max Principal (precise)	94452	n/a	83
	Margin of Safety	97551	n/a	0.19
	Failure Index	97551	n/a	0.84

### 6.4.3 Excitation Frequencies

One of the key benefits of the Random Processor is that the user does not need to define excitation frequencies and worry about specifying either too few or too many: The solver automatically determines the excitation frequencies on a request-by-request basis, thereby removing any concerns about trading off performance versus accuracy.

# 7. Unprecedented efficiency and performance in random base excitation

The SAToolkit Random Processor is a best-in-class tool for the simulation of base-driven random vibration. It utilizes an efficient and optimized modal approach to evaluate the dynamic response of a structure subjected to a base acceleration power spectral density function.

The Random Processor leverages a parallelized standalone solver as well as advanced integration and proprietary algorithms for a faster solution time: At computing Von Mises and tensor stresses for a benchmark FEM containing about 110,000 elements, it's over 11,000X faster than Simcenter Nastran SOL 111. The Random Processor processes any combination of requested results types and formats in a single solution. The solver can be launched from the command line on a remote server, thereby avoiding desktop locking.

The Random Processor computes Peak results that correspond to a desired confidence level for a number of random responses, including Von Mises, principal and maximum shear stresses and strains, failure metrics for homogeneous elements, phase-consistent magnitudes for vector results as well as composite failure metrics like Tsai-Wu margins of safety. Manually scaling RMS results is no longer required, improving both workflow and accuracy: Errors of up to 25% were identified when using the traditional workflow of scaling RMS Von Mises stresses in the benchmark FEM. Manually defining excitation frequencies is also no longer required, which can prevent significant errors. The Random Processor also computes PSD XY functions and the number of positive zero crossings.

The Random Processor computes RMS results that are within 1% of equivalent, meaningful results from Nastran SOL 111: Users can safely migrate to the Random Processor and benefit from its superior performance and accuracy.

## 8. References

---

1. **Jacques Desfossés, Philippe Tremblay and Andrew MacLean, ACCURATE ESTIMATION OF PEAK VON MISES STRESS AND COMPOSITE FAILURE METRICS IN RANDOM SIMULATION,** presented at NAFEMS 2015 World Conference.

# Maya HTT

