

Aerospace

ATK Aerospace Group

Integrated design and analysis pays off on the design of NASA's next-generation launch vehicle

Products

NX, Teamcenter

Business challenges

Redesigning launch-pad structures for adequate clearance and increased loads to accommodate new rocket's larger nozzle

Keys to success

Integrated design and analysis (FEA and motion) using NX

No data translation

Management of CAE processes and data using Teamcenter

Results

Faster creation of analysis models

Higher confidence in accuracy of analysis models; less time spent checking them

Analysis plays a greater role in the design process

Less analysis rework

Use of NX CAE for motion and finite element analysis – in an integrated process managed with Teamcenter – helped engineers ensure that a larger nozzle won't hit launch-pad structures during lift-off

The biggest, most capable rocket ever built

ATK Aerospace Group (ATK) is the world's top producer of solid rocket propulsion systems and a leading supplier of military and commercial aircraft structures. It also specializes in small and micro-satellites; satellite components and subsystems; lightweight space deployables and solar arrays; low-cost, quick-to-market launch solutions; flares and decoys; and energetic materials and related technologies. The group also has extensive experience supporting human and space payload missions.

One of ATK's current projects involves the Space Launch System (SLS), which is the successor to the Space Shuttle. NASA describes the SLS as "the biggest, most capable rocket ever built for entirely new human exploration missions beyond earth's orbit." The SLS will be NASA's first exploration-class vehicle since the Saturn V took American astronauts to the moon over 40 years ago, but the SLS will take astronauts farther into space, eventually including missions to Mars. Its first flight is scheduled for 2017.

Photo courtesy of NASA.



“We’ve had a long-standing partnership with Siemens.”

Ramesh Krishnan
Senior Staff Engineer
Engineering Processes and
Tools Group
ATK Aerospace Group

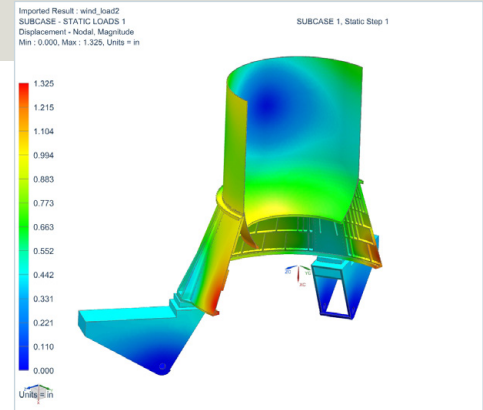
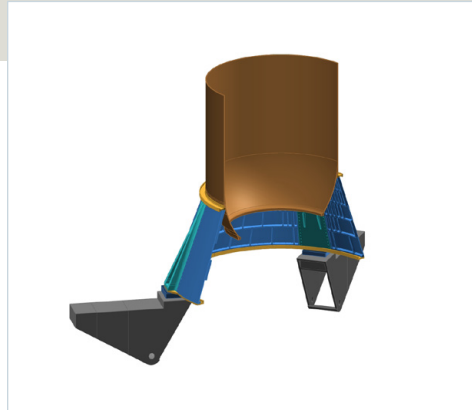

ATK’s work involves the SLS’s solid rocket boosters, the twin external structures on either side of the core stage, that provide extra thrust for the first two minutes of flight. Early SLS missions will use modified Space Shuttle solid rocket boosters, which ATK also designed. ATK’s current work, however, involves designing advanced boosters that will have more thrust and be used on later SLS missions carrying bigger payloads.

Bringing CAE into the PLM environment

ATK has used product lifecycle management (PLM) technology from Siemens PLM Software for nearly a decade, utilizing NX™ software for design and Teamcenter® software to manage product information and processes. “We’ve had a long-standing partnership with Siemens PLM Software,” says Ramesh Krishnan, a senior staff engineer in the ATK’s Engineering Processes and Tools group. “It started with visionary leadership who saw the benefits of an integrated system.”

In recent years, the group has been working to better integrate analysis into the design process. “Our challenge is to integrate CAE [computer-aided engineering] engineers early in the product development cycle so we can impact design,” says Nathan Christensen, senior manager of Engineering Tools and Analysis at ATK. “This can be a tall order given our nature as engineers and the complexity of our tool set.” The work being done for the SLS program related to the advanced booster rocket’s nozzle offers a good illustration of how they are meeting this challenge.

“The size of the nozzle is going to increase quite a bit to get better performance out of our motors,” explains Krishnan. “There are a lot of structures that a larger nozzle could possibly hit on its way up off the pad.” The aft end of the booster has a skirt, and attached to that skirt are launch mounts that hold the rocket in place while it is on the launch pad. ATK is designing retractable mounts – a first for ATK – that will retract at launch so the nozzle won’t hit them.

“We believe that significant cost savings and productivity gains can be accomplished with careful and strategic CAE tool standardization.”

Nathan Christensen
Senior Manager
Engineering Tools and Analysis
ATK Aerospace Group

Using NX, ATK modeled the aft end of the booster, including the skirt and the retractable launch mount assembly. That digital geometry was then used for two different types of analysis, motion analysis and finite element analysis (FEA).

Retractable mounts and hurricane-force winds

ATK used NX Motion to simulate the movement of the launch mounts during the rocket's lift off. "For the speed of the rocket, we used a curve that we input into Excel and then linked the motion simulation speed to that spreadsheet," Krishnan explains. "That was thrust versus time, and it worked quite well. The rocket took off with appropriate acceleration."

"The engineer working this project had never used NX Motion, but he picked it up quickly and figured it out; within a few days he had a full model working," says Krishnan. The simulation he created even includes a launch mount's 4-inch bolt, which drops away at launch due to a frangible nut. Using motion simulation, ATK soon got to the point where the launch mounts retracted correctly. "The main intent was to use NX Motion to capture the timing sequence of the rocket taking off and the retractable launch mounts moving back, and we did achieve that," he notes.

Next, the team undertook FEA. ATK had access to numerous FEA preprocessors and solvers. As part of the move to better integrate analysis and design, ATK is working to consolidate its CAE tools, making NX CAE and NX Nastran® software the stan-

dard applications and filling in with other solutions for functionality that NX doesn't support. "This way, engineers will use company standards, not favorites," Christensen explains. "It should reduce the costs we have now of supporting multiple tools with similar functionality, and it will facilitate the hand-off of work between analysts."

Starting with design geometry, ATK used NX CAE to prepare the finite element model of the booster rocket's aft assembly. "Many finite element modeling packages don't handle assemblies very well, but NX does," Krishnan explains. The best part of working with NX CAE, in his opinion, is that changes made to the assembly model are maintained in the finite element model. "What's really nice is the ability to make modifications in the modeling portion and transfer those over to FEA," says Krishnan. "It's very seamless. The mesh automatically updates and it's very convenient. Also, you maintain associativity. All the connections you've made in the assembly stay in the assembly all the way through the FEA. You don't have to try to move stuff around in the FEA."

ATK also liked the ease of creating geometry using NX CAE. "We like that we could model the bolts very quickly as beam elements and spider elements," Krishnan explains. "We could take these parts that were free-floating in space and tie them all together with a tool that allows you to select all surfaces or edges of the bolt hole, and it automatically creates beam elements. That saved a lot of time."

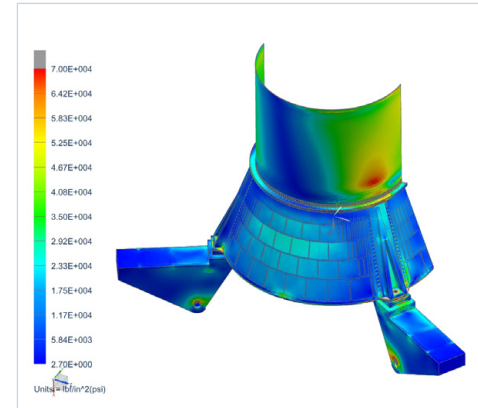

“Many finite element modeling packages don't handle assemblies very well, but NX does.”

Ramesh Krishnan
Senior Staff Engineer
Engineering Processes and Tools Group
ATK Aerospace Group

Solutions/Services

NX
NX CAE
NX Nastran
www.siemens.com/nx
Teamcenter
www.siemens.com/teamcenter

Customer's primary business

ATK Aerospace Group is the world's top producer of solid rocket propulsion systems and a leading supplier of military and commercial aircraft structures.
www.atk.com

Customer location

Brigham City, Utah
United States

"What's really nice is the ability to make modifications in the modeling portion and transfer those over to FEA."

Ramesh Krishnan
Senior Staff Engineer
Engineering Processes and
Tools Group
ATK Aerospace Group

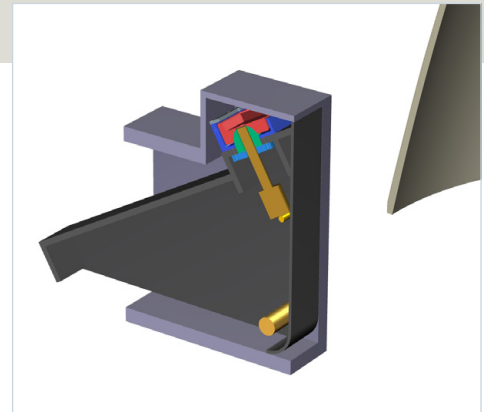
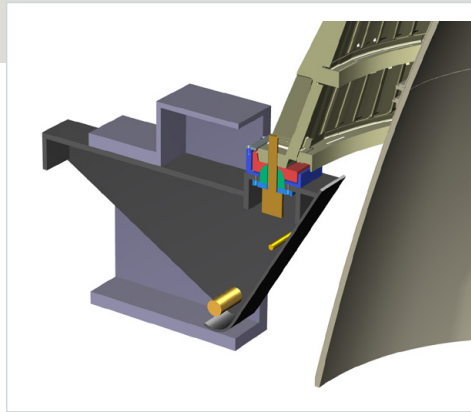

Although ATK did some FEA to determine whether the launch mounts were strong enough to handle their loads, more of the FEA was directed at the aft skirt, the interface between the rocket and the launch pad, which must withstand the weight of the rocket (2 million pounds axial load when empty of fuel; 7 million pounds when full) as well as wind loads (hurricane force). The loads involved were huge. "We've never dealt with loads of this magnitude in an aft skirt before," says Krishnan.

In addition to saving time, the more important benefit to ATK of NX integrated design and analysis was that it gave the company confidence that its model was accurate. "We had confidence that what we drew using NX was coming right over to the finite element package and that's what we were analyzing," Krishnan explains. ATK spent less time checking analysis model thanks to that. "Also, one of the problems with modeling contact in large finite element assemblies is you have to make sure you're line-on-line. With NX, you're line-on-line from the beginning. There's no fuss to maintain contact and make sure everything is in the correct location. It's always in the correct location." In addition, this process is less error-prone in general since there are no translations between software packages.

Integrating analysis into the design process includes the use of Teamcenter for managing CAE workflows, as well as the use of the Teamcenter data vault to store CAE models, results, reports and links to the product structures. "This helps ensure that we don't analyze the wrong parts or configurations, and that analysts stay in-sync with design changes, reducing CAE rework," notes Christensen. As with the company's design process, Teamcenter is also used to keep analysis projects on-track. The Teamcenter solution for reporting and analytics is used to track project status (on-time, projected late, and late), cycle time and first-pass yields.

Christensen summarizes the effect of standardizing on NX for analysis, and of better integrating analysis and design this way: "Integrating CAE tools early in product development shortens the design cycle, and lets us focus on overall design cycle times instead of analysis cycle times. Also, we believe that significant cost savings and productivity gains can be accomplished with careful and strategic CAE tool standardization. Most important, CAE is most effective if engaged early with the design team."

Siemens Industry Software

Americas +1 314 264 8499
Europe +44 (0) 1276 413200
Asia-Pacific +852 2230 3308

www.siemens.com/plm

© 2013 Siemens Product Lifecycle Management Software Inc. Siemens and the Siemens logo are registered trademarks of Siemens AG. D-Cubed, Femap, Geolus, GO PLM, I-deas, Insight, JT, NX, Parasolid, Solid Edge, Teamcenter, Tecnomatix and Velocity Series are trademarks or registered trademarks of Siemens Product Lifecycle Management Software Inc. or its subsidiaries in the United States and in other countries. Nastran is a registered trademark of the National Aeronautics and Space Administration. Excel is a registered trademark of Microsoft Corporation. All other logos, trademarks, registered trademarks or service marks used herein are the property of their respective holders.

Z14 34270 10/13 A