

OptiAssist for Simcenter 3D

Unlocking Nastran Design Optimisation

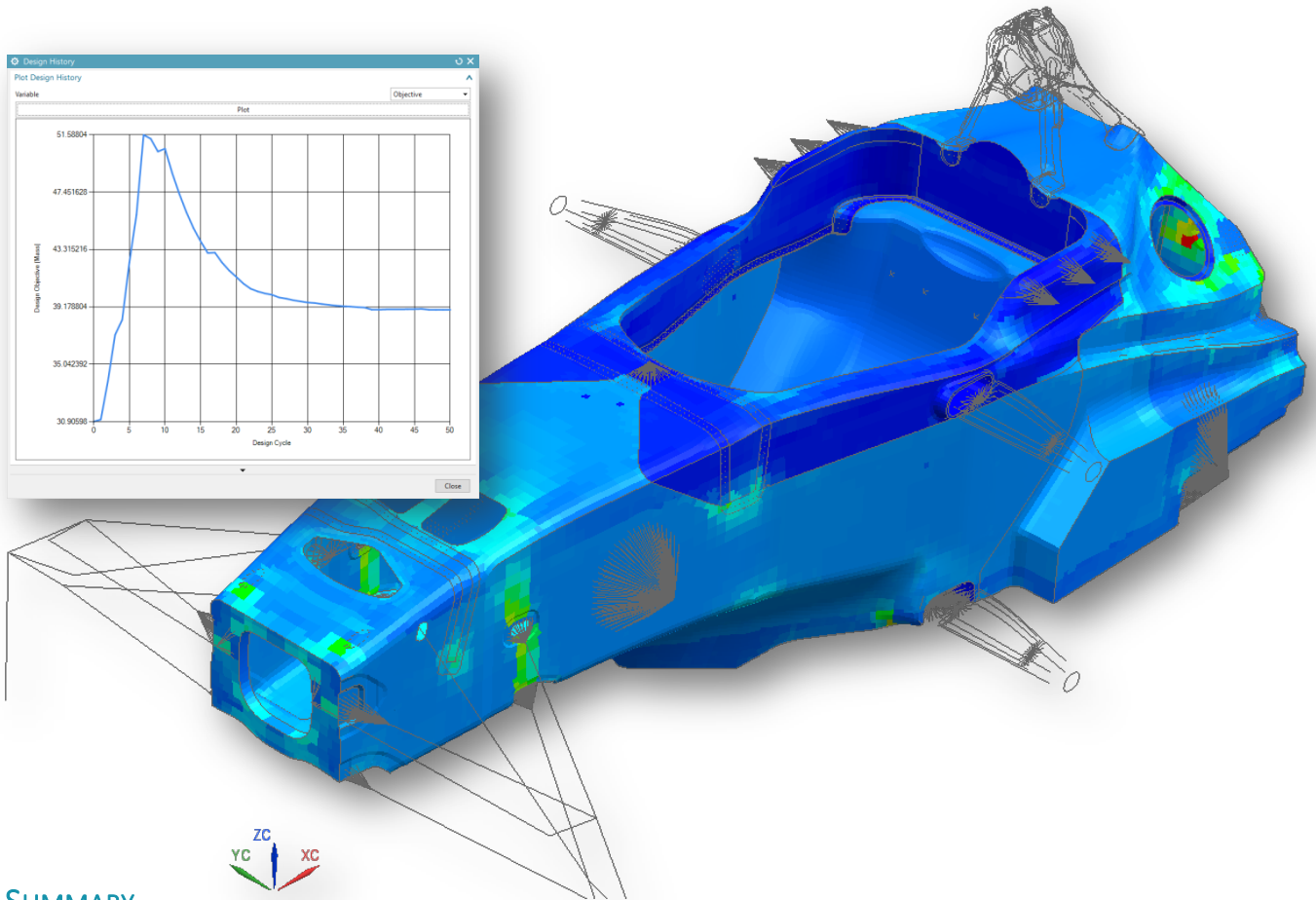

SUMMARY

OptiAssist for Simcenter 3D is a fully integrated add-in for Simcenter 3D users, designed to unlock the power of structural optimisation using the Nastran Optimisation module (SOL200). OptiAssist's objective is to deliver a unified optimisation environment that both extends the available structural optimisation methods and greatly simplifies the Simcenter 3D interface to Nastran. Using OptiAssist allows engineers to rapidly deliver high performance, lightweight products within a short timeframe. Using OptiAssist for Simcenter 3D, the following optimisation solutions are available.



A Pedigree of Success in Formula 1®

Developed through 16 years of continual work with leading Formula 1® teams, OptiAssist's composite laminate optimisation techniques have been refined to be robust and efficient. Working with teams such as Red Bull¹, Renault F1², Force India³ and Caterham F1⁴, OptiAssist has been used by the Formula 1® Team winning the driver's Championship for 14 of the last 15 years.

- 1 - *Development Of Composite Laminate Optimisation Techniques Using Topometry Optimisation In Genesis*, Lewis Butler, Red Bull Racing Ltd, 2006
- 2 - *Optimised Roll Hoop Design Methods*, Richard White, Renault F1, 2016
- 3 - *A Comparison Of Optimisers In The Application Of Formula 1 Monocoque Design*, Dr. Simon Gardner, Force India, 2008
- 4 - *Case Studies in Composite Laminate Optimisation*, Adam Moore, Caterham F1, 2013



OptiAssist for Simcenter 3D provides efficient optimisation work trails within Simcenter 3D, automatically preparing the Nastran optimisation (SOL200) solution data based upon the user's setup. Users may select their existing Nastran solution / subcase objects and OptiAssist will automatically migrate these to the optimisation solution set. Version 2.0 supports static and dynamic modal solution types. Within the OptiAssist trails users may consider the following structural responses:

- Displacement
- Stress
- Failure Index
- Frequency
- Mass
- Global Stiffness (Strain Energy)

Further to managing the optimisation data creation, solution, post-processing and model update, all data created by OptiAssist is stored in the Simcenter model tree, allowing direct further editing for more experienced users.

Through the OptiAssist interface, engineers are able to efficiently develop their products, seamlessly integrating optimisation into their engineering development cycle.

A Platform for Unlocking Design Optimisation

Design optimisation techniques are not new, but their adoption into engineering developments remains relatively low; often applied by an 'optimisation expert.' OptiAssist for Simcenter 3D builds on GRM's experience of applying design optimisation to real world engineering developments, providing an interface that guides engineers, allowing them to unlock the capabilities of design optimisation.



Key Software Processes

OptiAssist for Simcenter 3D provides 4 optimisation workflows, each allowing different methods of changing a part's design. These are Thickness, Topography, Free-shape and Composites. Each workflow allows for automated optimisation of a design to be applied, eliminating the costly and inefficient process of manual iteration.

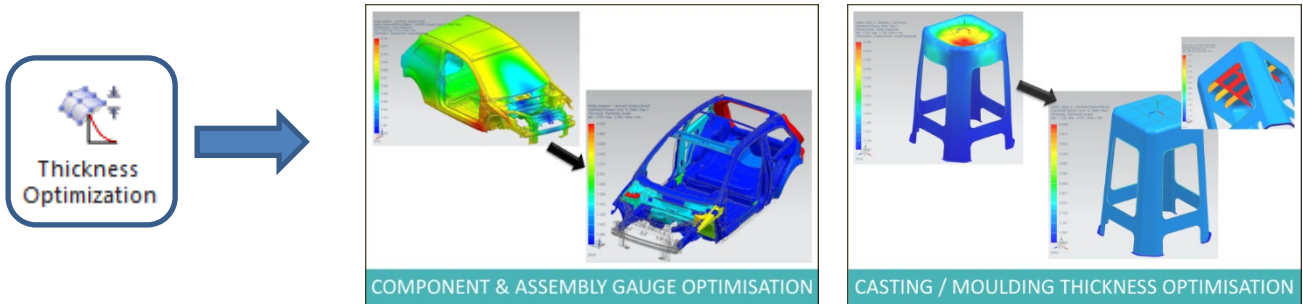

Gauge Sizing – Develop optimal thickness of thin shell structural components and assemblies. The process is well-suited to maximising stiffness or natural frequency of a design or minimising stress.

Free-Sizing / Topometry – Develop thickness distribution of thin shell structures. The process is suitable for automatically developing the optimal thickness of castings, mouldings and thin shell machined parts.

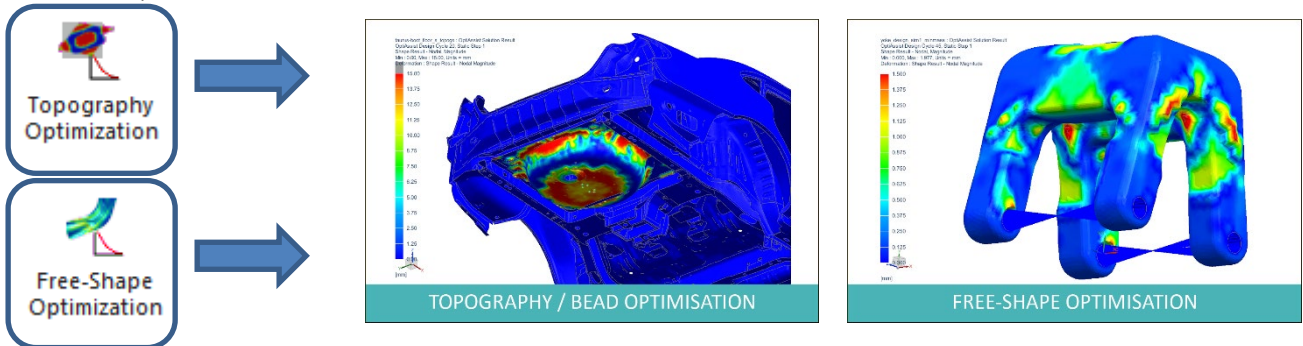

Bead / Topography – Develop reinforcing patterns in thin shell structures. The process improves performance for no mass increase for stiffness, frequency and stress.

Free Shape – Refinement of a design's performance through nodal position changes. Suitable for resolving localised stress and stiffness issues.

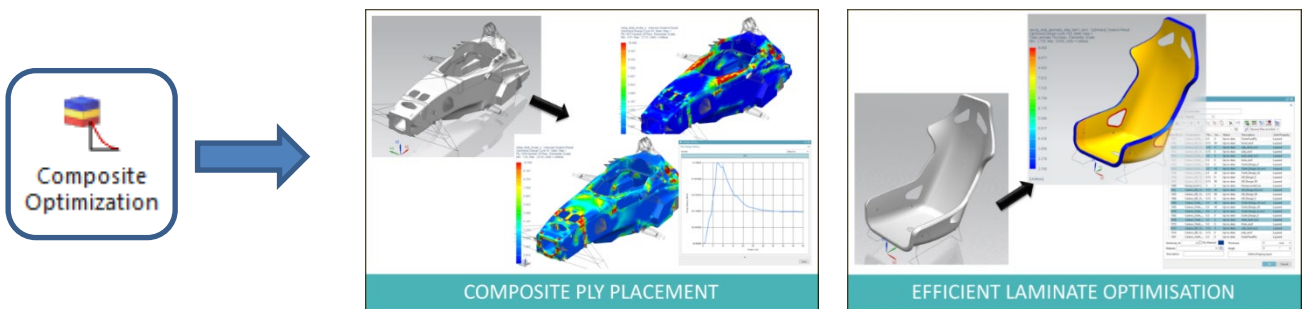

Composites – Develop optimal ply shapes and laminates. Provides a complete toolset for developing optimal laminates for multiple loading requirements.

MARINE – MEETING THE DESIGN CHALLENGE OF THE AMERICA’S CUP



The America’s Cup is the world’s oldest international sporting trophy and the pinnacle of sailing technology. For the current set of rules (AC75 Class Yacht), teams must engineer a 75 foot hydrofoiling monohull design to compete in the event. INEOS Team UK’s technical team have adopted OptiAssist for Simcenter 3D to provide a competitive advantage in their structural developments.

Competition Drives the Approach at Every Level

“In such a competitive environment, every of piece of the design is focussed on.” INEOS’ philosophy for development of their design is to utilise OptiAssist’s techniques at every level of design, including:

- Global – (eg. Hull Laminate Reinforcement)
- Sub-assembly – (eg. Mast Bulkhead Laminate)
- Components – (eg. Drivetrain Bracket)

Through using OptiAssist for Simcenter 3D, INEOS Team UK has been able to develop optimal composite ply shapes without the need to have pre-conceived ideas of ply boundaries. Incorporating OptiAssist early on has given them the flexibility at the conceptual stage to rapidly evaluate and compare different design schemes. By allowing them to turn around concepts more quickly, they have been able to deliver more in the competitive development race to win.

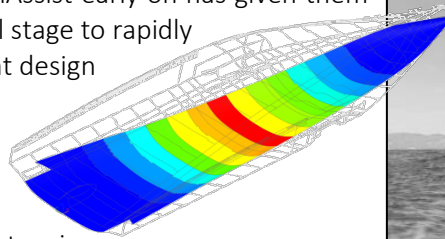

BENEFITS OF USING OPTIASSIST FOR SIMCENTER 3D

- Eliminate costly manual iteration time
- Maximise a design’s performance for multiple requirements
- Seamlessly perform structural optimisation tasks inside the Simcenter 3D environment
- Shorten laminate development times and reduce engineering iteration overhead
- Maximise potential of composite materials through optimisation
- Seamlessly integrate powerful optimisation tools into your engineering team

COMPATIBILITY & PRE-REQUISITES

As a direct add-in to the Simcenter 3D environment, OptiAssist provides an optimisation environment for Simcenter 3D that works directly with the native model data. OptiAssist for Simcenter 3D supports Simcenter 3D releases 2019.1 onwards. Composite capabilities work with both the standard Simcenter 3D composite model and the extended capabilities of the Laminate Composites module. OptiAssist requires Simcenter 3D, Simcenter Nastran and its Design Optimisation module.